

# OPERATOR'S MANUAL

# *20KW*

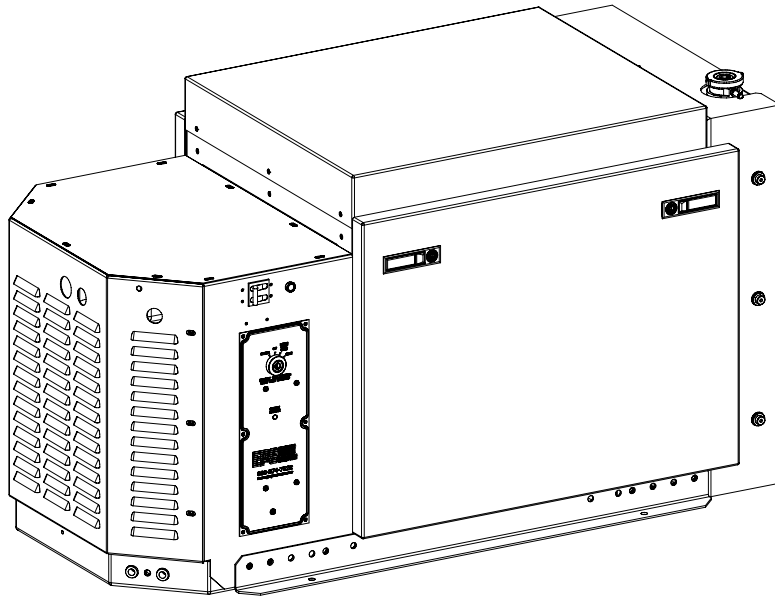

20KW-IN-A-BOX MANUAL.DOC REV F 1/16/06

***VERY  
IMPORTANT!***

**BEFORE DOING ANY WORK  
ON THE ELECTRICAL PANEL OR ON THE  
ENGINE-GENERATOR SET,  
DISCONNECT THE POSITIVE (+)  
BATTERY CABLE!**

## TABLE OF CONTENTS

---

SAFETY PRECAUTIONS .....	4
SPECIFICATION TABLE .....	5
OVER-ALL VIEWS .....	6
INSTALLATION – APPLICATIONS .....	8
INSTALLATION – MOUNTING LOCATION .....	8
INSTALLATION – MOUNTING SPECIFICS – ENCLOSED MODELS .....	9
INSTALLATION – MOUNTING SPECIFICS – NON-ENCLOSED MODELS .....	10
INSTALLATION – AIRFLOW CONSIDERATIONS .....	11
INSTALLATION – COOLANT RESERVE TANK .....	15
INSTALLATION – FUEL CONNECTIONS .....	16
INSTALLATION – BATTERY CONNECTIONS .....	18
INSTALLATION – REMOTE START PANEL .....	20
INSTALLATION – OPTIONAL DELUXE GAUGE PANEL .....	21
INSTALLATION – AC ELECTRICAL CONNECTIONS .....	22
OPERATION – STARTING AND STOPPING .....	24
ROUTINE MAINTENANCE – ENGINE OIL & FILTER .....	25
ROUTINE MAINTENANCE – FUEL FILTER .....	26
ROUTINE MAINTENANCE – AIR CLEANER .....	26
ROUTINE MAINTENANCE – RADIATOR & COOLANT .....	27
ROUTINE MAINTENANCE – FAN & ALTERNATOR BELT .....	27
ROUTINE MAINTENANCE – ELECTRICAL WIRING .....	27
TROUBLESHOOTING – PRINCIPLES OF OPERATION .....	28
TROUBLESHOOTING – DIAGNOSING SHUTDOWNS .....	31
TROUBLESHOOTING – LOW OIL SWITCH .....	31
TROUBLESHOOTING – HIGH TEMPERATURE SWITCH .....	33
TROUBLESHOOTING – FUSES .....	35
PARTS LISTS .....	38
SCHEMATICS – OPTIONAL REMOTE START GAUGE PANEL .....	40
SCHEMATICS –MOBILE GENSET .....	41

## SAFETY PRECAUTIONS

---

Read this **OPERATOR'S MANUAL** *carefully* before installing or operating the generator.

**SYMBOLS:** This manual uses the following symbols to alert you to potential hazards to the operator, servicing technician or unit.

 **DANGER** alerts you to immediate hazards that can result in severe injury or death.

 **WARNING** forewarns you of an unsafe practice or hazard that could lead to severe injury or death.

 **CAUTION** warns you of an unsafe practice or hazard that could lead to injury or damage to the equipment.

### **GENERAL PRECAUTIONS:**

- ◆ Read and understand this manual before installing or operating this unit. If there is something you do not understand or need to know, contact Cummins Atlantic before proceeding. If in doubt, ask!
- ◆ Before working on the Generator, always disconnect the positive (+) battery cable to prevent unexpected starting or short circuits.
- ◆ Keep a fire extinguisher within reach. Use type ABC extinguishers, only.
- ◆ Keep the generator and the surrounding area clean. Grease, oil, diesel fuel, dirty rags, etc. are all flammable and can cause a fire.
- ◆ Keep sparks and flame away from the generator and battery. Do not smoke while working on or around the generator.
- ◆ Make sure that all fasteners, guards and loose parts are installed and properly tightened down before starting the unit. Loose parts can easily vibrate out and be thrown by the fan or fan belt, causing injury or death.
- ◆ Assure that there is adequate ventilation for the exhaust. Exhaust fumes are odorless, colorless and deadly! Do not run the unit indoors where exhaust fumes can accumulate.
- ◆ Keep your hands and body away from moving parts. Do not wear loose clothing, which can become entangled in moving parts, and pull you in.
- ◆ Keep hands and body away from hot parts that can burn you. The engine, generator end, radiator, radiator tank and hoses all get very hot after running. Never attempt to work on a hot cooling system – radiators are under pressure and can blow hot steam and water off, causing severe burns. Always allow the unit and cooling system to cool down fully before working on the unit.
- ◆ Antifreeze, oil and diesel fuel are all poisonous and dangerous to the environment. Avoid direct contact with these fluids and dispose of them properly. Always wipe up any of these fluids that are spilled.



# SPECIFICATIONS

**TABLE 1: UNIT SPECIFICATIONS**

<b>ENGINE</b>	
MAKE	KUBOTA
MODEL	V2203 BG
NO. OF CYLINDERS	4
BORE X STROKE	87.0mm X 92.4mm (3.43" X 3.64")
TOTAL DISPLACEMENT	2.197 L (134.08 cu-in)
INTAKE SYSTEM	NATURALLY ASPIRATED
HP @ 1800 RPM (NET INT.) †	30.6 HP
HP @ 1800 RPM (NET CONT.) †	27.1 HP
FUEL	#2-D DIESEL (ASTM D975)
ALTERNATOR	40 AMPS
<b>GENERATOR END</b>	
MAKE	MARATHON
MODEL	334CSB3028
KILOWATTS CONT. (1.0PF) †	17.5
KILOWATTS STAND-BY (1.0PF) †	20.0
120/240V SINGLE PHASE CONT. AMPS	146/73
VOLTAGE REGULATION	AVR CONTROLLED
VOLTAGE REGULATOR	SE350 (240V)
EXCITATION	BRUSHLESS EXCITER
INSULATION CLASS	F
<b>FUEL CONSUMPTION</b>	
25% LOAD	0.61 US Gal./hr.
50% LOAD	0.97 US Gal./hr.
FULL-LOAD (17.5 KW)	1.58 US Gal./hr.
<b>WEIGHTS AND MEASURES</b>	
WEIGHT (INCL. OIL & ANTIFREEZE)	925 lbs.
ENCLOSURE LENGTH	47.12"
ENCLOSURE WIDTH	24.00"
ENCLOSURE HEIGHT	26.03"
OIL CAPACITY	8 US quarts
SOUND LEVEL (HALF LOAD)*	70.7 dB(A) @ 7m
SOUND LEVEL (FULL LOAD)*	70.3 dB(A) @ 7m

with all 3 generator cooling vents open. A typical installation will result in lower sound levels.

† All unit ratings are established at 1.0 power factor, 68° F and 500 ft. above sea level. De-rate unit by 3.5% for every 1000 ft. above 500 ft. and 1% for every 10° F above 68° F.

\* Sound Level

# OVER-ALL VIEWS

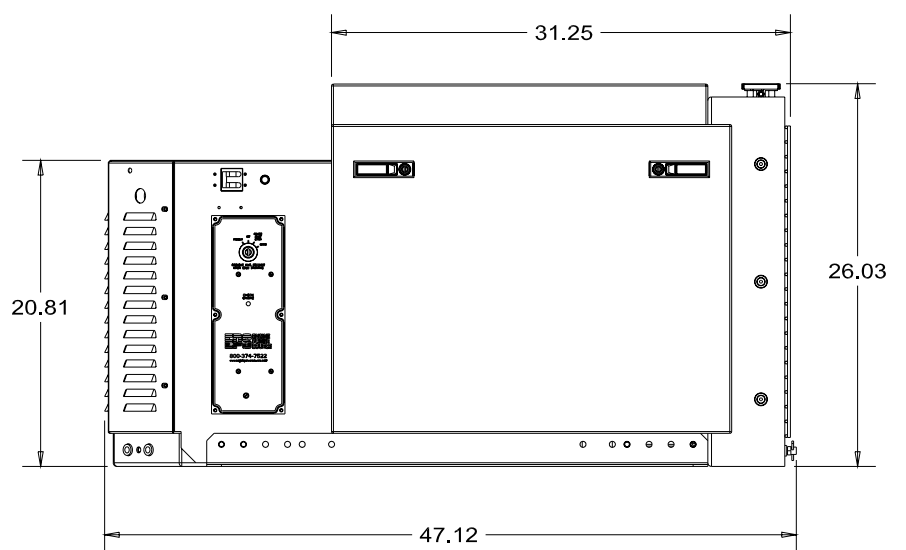
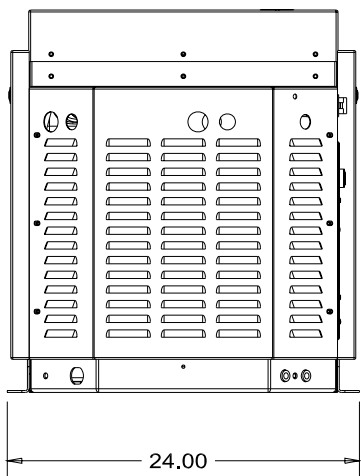
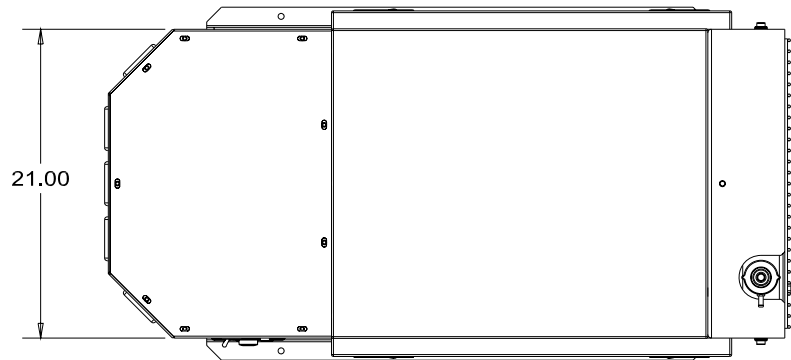

# OVER-ALL VIEWS

FIG. 2 STANDARD NON-ENCLOSED MODEL

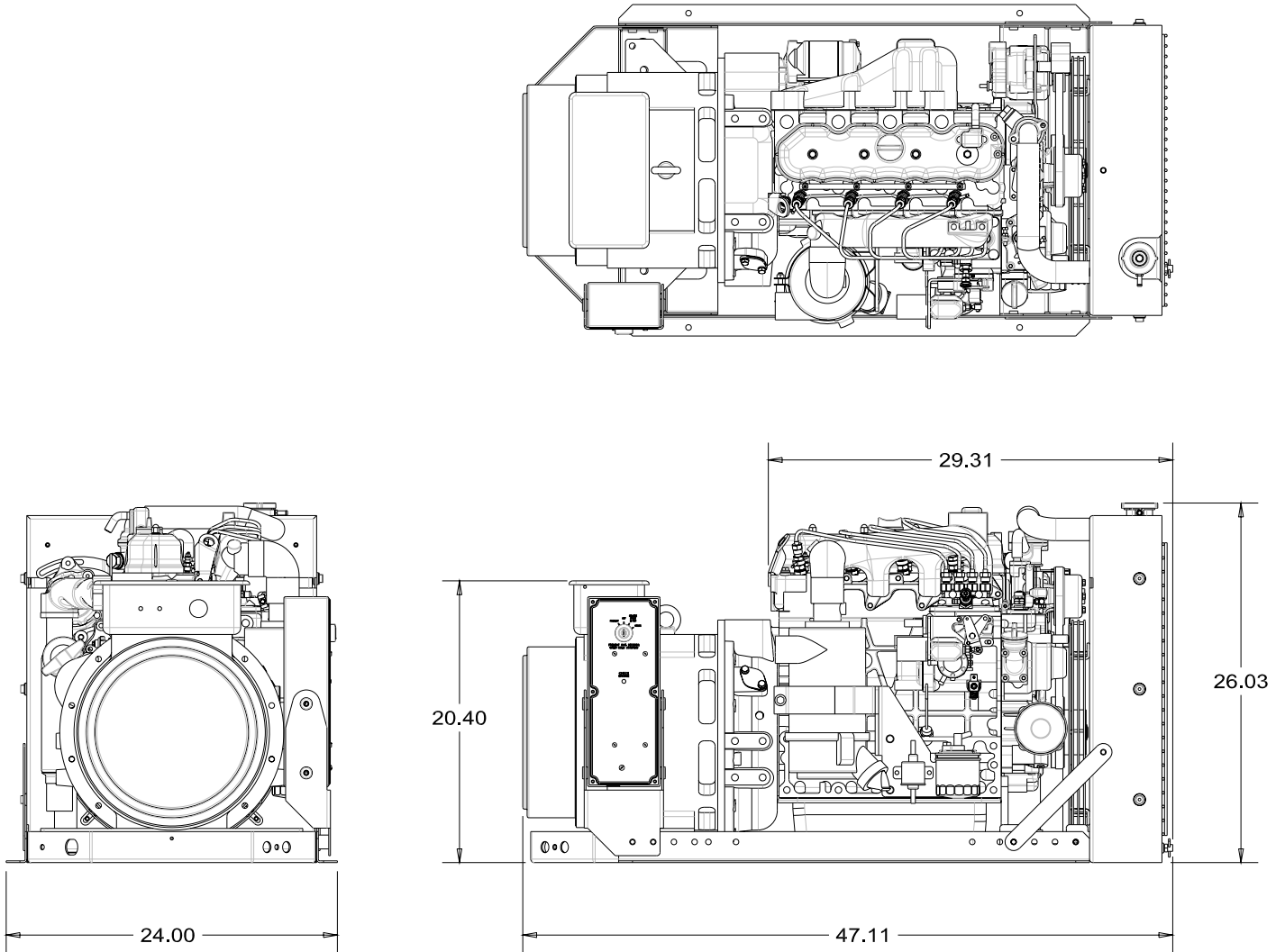

<b>WEIGHTS AND MEASURES (NON-ENCLOSED)</b>	
WEIGHT (INCL. OIL & ANTIFREEZE)	845 lbs.
UNIT LENGTH	47.11"
ENCLOSURE WIDTH	24.00"
ENCLOSURE HEIGHT	26.03"
OIL CAPACITY	8 US quarts
SOUND LEVEL (HALF LOAD)	73.2 dB(A) @ 7m
SOUND LEVEL (FULL LOAD)	72.7 dB(A) @ 7m



# INSTALLATION

## **APPLICATIONS**

This generator is designed to be mounted in various ways and in various locations on motor coaches, work trucks and toter-homes. Various recommended mounting configurations are shown in this section. Needless to say, nearly every installation is a little bit unique, and may require modifications to installations shown in this manual. When evaluating alternative installations, use the information and tips in this section to determine if your installation is going to work or not. If in doubt, contact Cummins Atlantic's Engineering Department for assistance in evaluating your installation.

Additionally, some "difficult" applications involving high levels of shock and vibration, or harsh environments, may require additional consideration to assure a robust and durable installation. Off-road equipment, oil-field equipment, and marine environments are just some of the applications that may require extra attention. Various options not listed in this manual are available to address issues like high vibration and salt water that might be encountered. Contact Cummins Atlantic's Engineering Department for assistance in evaluating any "difficult" application.

## **MOUNTING LOCATION**

Pick a Strong Mounting Point: The frame or floor that the generator is to be mounted to must be strong enough to support the load of the generator and hold it in place in the event of an accident.

 **WARNING: The generator must be mounted securely to prevent it from breaking free in the event of a sudden stop or crash. A dislodged generator can strike a person, causing severe injury or death.**

Consider the Added Weight: When choosing a mounting location, you must consider the effects of the added weight of the generator. Choose a location that will not degrade vehicle braking or handling performance. Also consider whether the location will overload one side of the vehicle, causing it to "list" to the side.

 **WARNING: Weight distribution can affect vehicle handling braking performance. Check with the vehicle chassis manufacturer to make sure that the location of the generator will not adversely affect vehicle handling and braking.**

Consider the Cooling Air Flow: It is very important to choose a mounting location that will provide adequate cooling airflow into the generator, while also allowing the warm air to be discharged. Without a doubt, this is the most important part of the installation from a performance and longevity standpoint. Oftentimes, the location that you would *like* to put the generator in will not provide the best cooling performance. It is far better to sacrifice some convenience in order to insure good operating performance and a long life for your generator.

 **CAUTION: Inadequate airflow to and from the generator can lead to reduced life or permanent and expensive damage to the engine and/or generator end. Install your generator per the guidelines listed below.**

## MOUNTING SPECIFICS – ENCLOSED MODELS

When mounting directly to the floor of a vehicle, holes must be cut into the floor to allow cooling air to flow through the bottom of the generator. Cutting holes will generally weaken the floor structure to some extent – this must be taken into consideration when evaluating your installation. If necessary, add additional support frame members, plywood or sheet metal to compensate for the loss in floor strength.

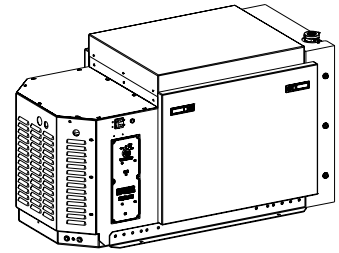

FIG. 3 MOUNTING POINTS – ENCLOSED MODELS

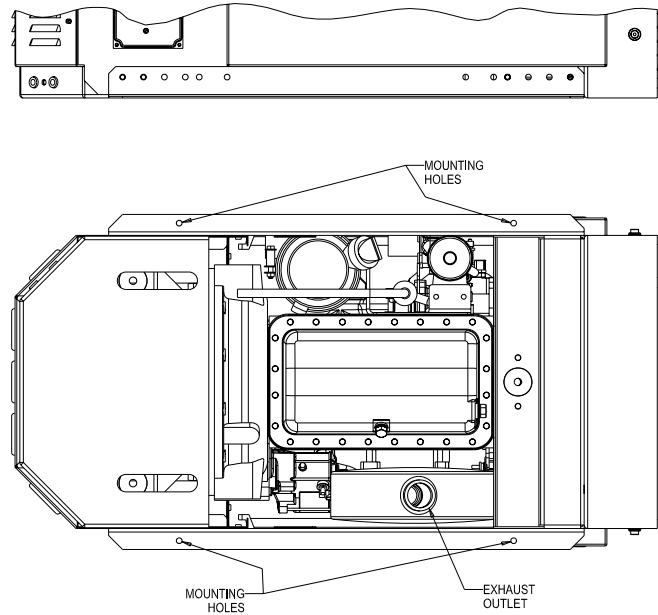
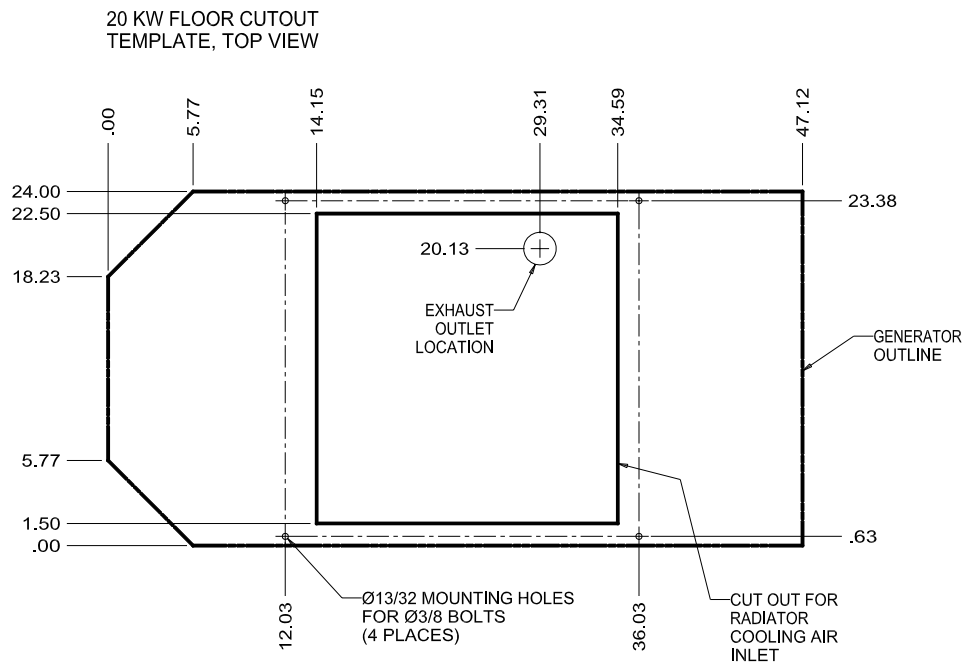
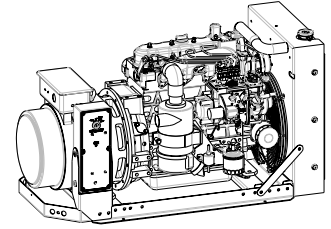

FIG. 4 FLOOR CUTOUT TEMPLATE – ENCLOSED MODELS



## **MOUNTING SPECIFICS – NON-ENCLOSED MODELS**

On the fully-enclosed models, airflow to and through the unit is carefully controlled by the design of the enclosure. Unlike the enclosed model, the non-enclosed models require the installer to carefully consider the air-flow to and from the unit. In essence, the bus bay or compartment becomes the generator enclosure. It takes some understanding and experience to assure that cooling issues will be avoided. The following instructions should be used as a general guide to aid in designing an installation. Due to the multitude of ways a generator can be installed in a compartment or bus bay, no specific installation details can be provided. Contact CUMMINS ATLANTIC's Engineering Department for advice on specific installation designs.



**⚠ CAUTION: Poor installations that starve the unit for cooling air or cause recirculation of hot air can result in engine over-heating problems and/or severe damage to the generator end.**

**FIG. 5 FLOOR CUTOUT TEMPLATE – NON-ENCLOSED MODELS**

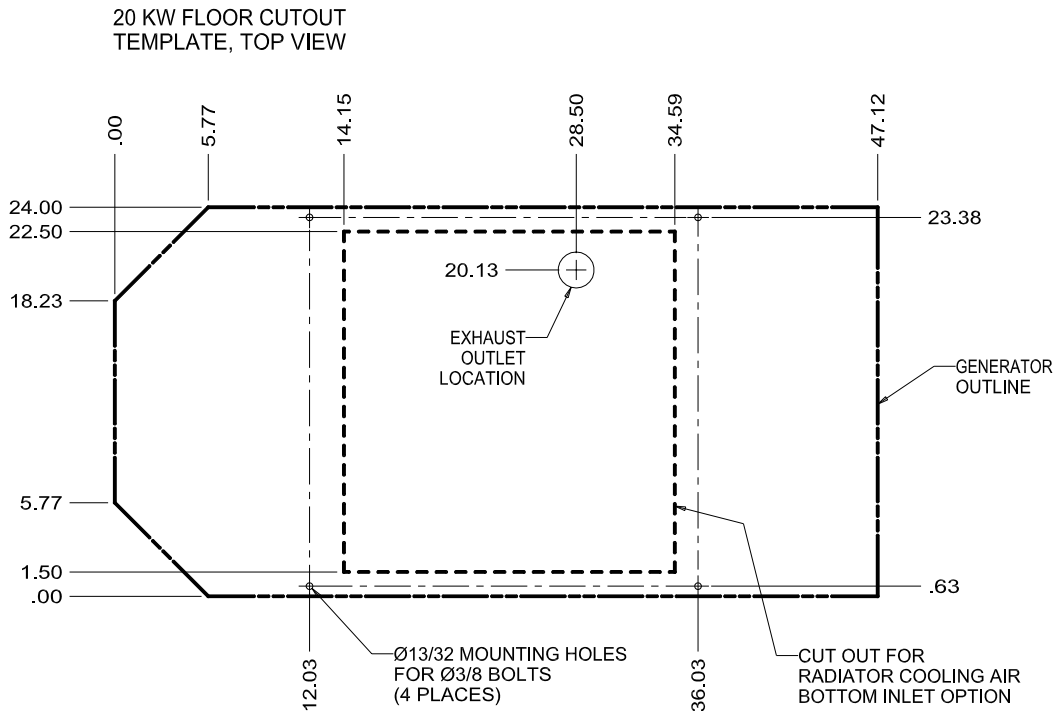

**NOTE:** On fully-enclosed models, the bulk of the cooling air must be brought in through the bottom of the unit. On non-enclosed models, radiator cooling air can be brought in through the bottom or alternatively, the bottom can be blocked off and the cooling air be brought in from behind the generator end. Both of these options for the non-enclosed unit will be discussed later in this section.

FIG. 6 AIR FLOW DIAGRAM - ENCLOSED MODELS

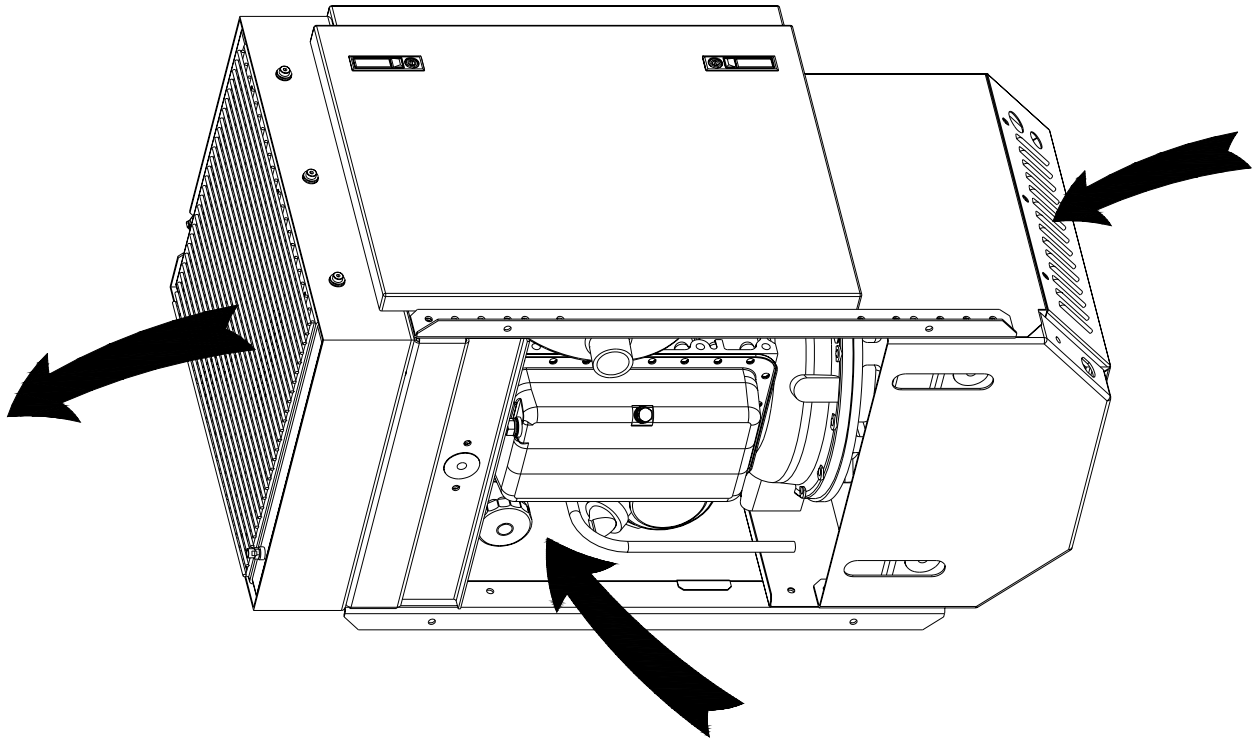
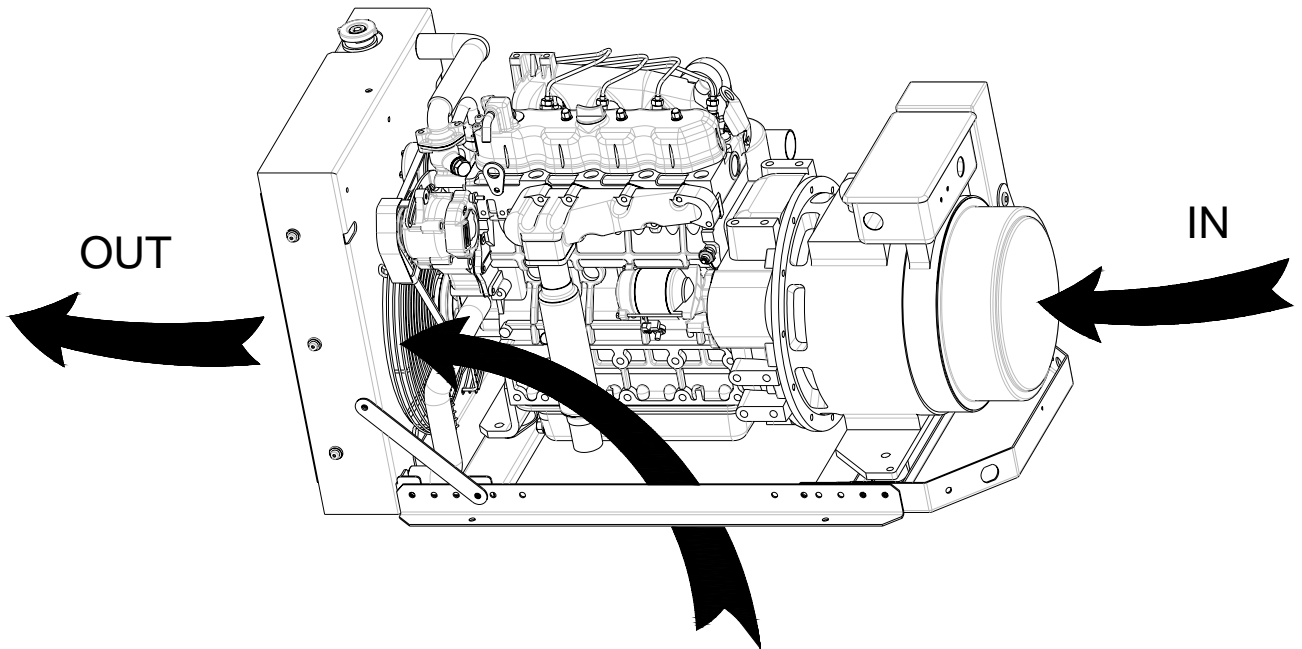

FIG. 7 AIR FLOW DIAGRAM - NON-ENCLOSED MODELS  
STANDARD METHOD - COOLING AIR THROUGH BOTTOM



*Provide Cool Air for the Generator End:* The generator end requires plenty of cool air to cool the windings. Whereas the engine has an over-temperature shutdown that will prevent damage, the generator end does not. If adequate cool air is not provided to the generator, oftentimes the first indication of a problem is the smell of burnt windings! To avoid generator-overheating problems, consider the following when installing the unit:

- When installed in a secondary enclosure or bay, provide an opening of at least 64 square inches very near or directly behind the rear of the generator, (8"x8", for instance). This opening should provide the coolest air possible. It is very important that the hot air from the radiator not be allowed to re-circulate back to the air intake.
- To insure that the generator is getting cool air to it, use a thermometer to measure the temperature of the air directly at the rear of the generator while it is running under load for at least 30 minutes. Measurements should be taken right at the louvers in the rear cover and should not be more than 10° F hotter than the outside ambient air. If it is, it is likely that some hot air recirculation is taking place - which must be corrected.

**⚠ CAUTION: The generator end is designed for operation at a maximum ambient temperature of 40°C (104°F). Cooling air into the generator must not exceed 40°C (104°F).**

FIG. 8 AIR FLOW DIAGRAM – NON-ENCLOSED MODELS  
OPTIONAL METHOD – BOTTOM BLOCKED OFF

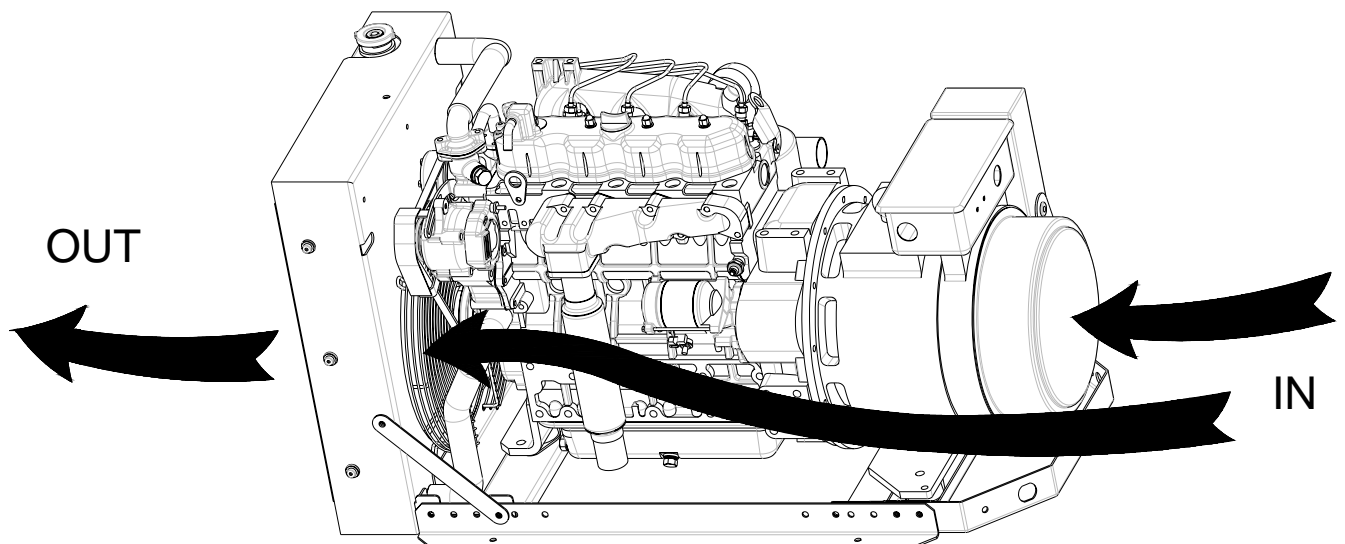

### Optional Cooling Air Method – Non-Enclosed Models ONLY:

As discussed previously, another method for providing cooling air for the non-enclosed models is to block off the bottom of the unit and bring the cooling air in from above. In this case, the mounting hole locations will be the same as shown in Figure 5, but the radiator cooling air cut-out *is not made*. Instead, cooling air for the radiator must be provided via another source. There are any number of ways to provide the required airflow – louvers in bay doors, a floor cut-out behind the generator end or an auxiliary blower moving cool air into the bay are just a few of the options.

If cooling air is to be drawn into the unit through holes in a compartment or bay by using the suction of the radiator fan, the total area of the inlet hole(s) must total to at least 1.5X the radiator core area – this amounts to about 540 square inches of inlet area. In the best designs, the cool air will pass directly by the cooling air louvers on the back of the generator end *before* being drawn through the radiator. In that way, it is assured that the coolest air is provided to cool the generator. This is typically accomplished by making sure the cooling air inlets are *behind* the generator end. If the cooling air inlets are located in any other position, it may be necessary to provide cool air from another source into the back of the generator to assure adequate cooling. Additionally, if the cooling air inlets are not behind the generator end, it is possible to create a condition where hot air from the generator air outlets is re-circulated back into the generator end inlet – causing it to overheat and burn up!

When using an auxiliary blower to force cool air into the compartment, locate the outlet of the blower so that it blows into the louvers of the generator end – generally speaking, this requires that the blower be mounted behind the generator end. In this way, this assures that cool air is provided directly to the generator and any additional air from the blower will “sweep” the hot air from the generator outlets toward the radiator.

### Radiator Airflow Considerations:

*Do not restrict Radiator Airflow:* It is very important not to restrict airflow through the radiator. If the unit is installed in a bus-bay, truck box or secondary enclosure of any kind, a hole of adequate size must be provided for the hot air from the radiator to pass through.

- “Straight Out” Designs: When the generator is installed so that the radiator blows directly out of the unit through a hole in the wall or door of a compartment, the opening should be the *same size or larger* than the radiator core and located directly in front of the radiator. If louvers or grill openings are used, the airflow will be restricted by the smaller openings, and the open area must be further increased to compensate for the restriction. Generally, openings with an area 50% greater than that of the radiator core will be sufficient. The radiator should be as close as possible to the opening to prevent hot air from re-circulating back to the generator air intake. If necessary, foam or rubber seals can be added between the radiator face and the hole to prevent any recirculation.

Most importantly, consider if the hot air being exhausted from the radiator can ever find its way back to the cooling air intakes – if it can, overheating problems can occur. In some cases, the airflow will work exactly as planned, until the vehicle is parked in close proximity to a wall or another vehicle, causing the hot air to “bounce back” and be re-circulated. Circumstances like this are difficult to anticipate, but must be considered in order to avoid the real-life problems that can - and will occur.

- “Through the Floor” Designs: Alternatively, a “plenum box” can be fabricated and added to the front of the radiator to blow the air through the floor of an enclosure or bay. Depending on the size and efficiency of the Plenum Box, the airflow will be somewhat restricted, resulting in a lower continuous power rating. When implementing a plenum box design, it is very important to incorporate some kind of “air scoop” or louver system to deflect the hot air away from the cool air intake holes under the unit. If simply allowed to exhaust its air straight down, most installations will result in serious engine over- heating problems due to the hot air re-circulating back into the air intake openings. Plenum boxes are a trade-off. They make the unit quieter, while sacrificing some wattage and valuable space. Larger, deeper boxes that have an outlet area *equal to the radiator core area* perform best and are the best bet to avoid over-heating problems. Many installations, however, cannot tolerate the space required by such a large box, and some cooling performance must be sacrificed in order to decrease the plenum size. An optional compact, high efficiency plenum box kit is available from the factory. It results in a decreased continuous rating of 15KW while only adding about 9-<sup>1</sup>/<sub>2</sub>” to the overall length . The kit includes the plenum box and a louvered grill to redirect the air away from cooling inlets. Contact CUMMINS ATLANTIC Generator Sales for availability and pricing.

FIG. 9 OPTIONAL  
PLENUM BOX

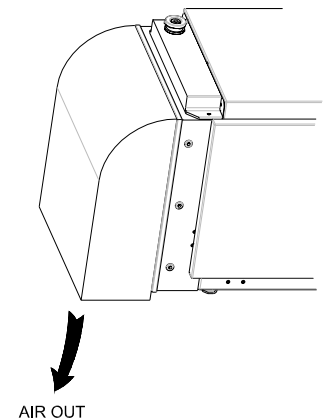

Exhaust Considerations: On fully-enclosed models, the muffler outlet exits through the cooling air opening in the bottom of the Drip Tray. Refer to Figure 4 for the exact location of the exhaust outlet relative to the mounting layouts. On non-enclosed models, a flexible exhaust connection is provided along with a muffler (shipped loose) - refer to Figure 5 for the location of the flexible exhaust outlet.

**⚠ WARNING: Exhaust gases produced by this generator are poisonous and can be lethal. Do not position the generator exhaust pipe where these gases can be drawn in through windows, doors, air conditioners, etc. If necessary, extend the exhaust pipe from the generator set to a safe discharge location. Carbon Monoxide is an odorless, colorless and tasteless gas, which if inhaled, can quickly overcome a person causing unconsciousness and death. Carbon Monoxide can accumulate in an enclosed area or in the open on windless days. Take care to park the vehicle so that exhaust fumes are directed down wind and away from other people, vehicles and buildings.**

On fully-enclosed models, a tailpipe must be attached to the exhaust outlet of the muffler to direct the exhaust fumes away from the vehicle. Since each application requires a unique tailpipe design, it is not furnished with the generator. The muffler is supplied with a 1-1/2” female NPT pipe outlet to allow easy adaptation to various tailpipe designs. Short tailpipes with few bends are the most efficient designs. If a tailpipe is abnormally long, (longer than 15 ft.), or if it employs sharp bends or several smaller bends, the diameter of the tailpipe should be increased to avoid restricting the exhaust flow.

On non-enclosed models, the muffler is shipped loose and the installer must fabricate the necessary connections between the flexible exhaust pipe on the unit and the muffler. Additionally, most installations will require a tailpipe to be fabricated to direct the exhaust from the muffler away from the vehicle. The flexible exhaust pipe is provided with a 1-<sup>3</sup>/<sub>4</sub>" I.D. exhaust pipe outlet. The Muffler has a 1-1/2" female NPT pipe inlet and outlet.

Some locations require the use of USDA approved spark arresters (National Parks, for instance). The standard muffler is shipped without a spark arrester. If your vehicle requires a spark arrester, contact Cummins Atlantic for availability and recommendations.

## **COOLANT RESERVE TANK**

The purpose of a coolant reserve tank is to allow the normal expansion and contraction of the coolant to take place as it heats up and cools off. As the coolant heats up, it expands and flows into the reserve tank. When the engine cools down, the coolant contracts and fluid is sucked back into the radiator from the reserve tank. In this way, the radiator is always kept 100% full, so that it can operate at its peak efficiency.

In normal operation, the coolant level in the recovery tank should be kept between the two level-lines on the recovery tank. Occasionally, it will be necessary to add a little coolant to the reserve tank to maintain these levels. As long as the reserve tank is kept from going dry, it should be unnecessary to add any coolant directly to the radiator. If the coolant tank does go dry, however, it may be necessary to top-off the radiator, in order to assure that it is full. When adding coolant, always add the same mixture as used in the radiator – in this manner, the proper water-to-antifreeze ratio will be maintained. Units are shipped from the factory with a 50/50 mixture of propylene glycol and water.



**WARNING: Do not attempt to remove the Radiator Cap with the engine running or on a hot engine. Allow the engine to cool down for at least 30 minutes before doing in maintenance involving the radiator or cooling system. Radiators are under pressure and can spray steam and hot coolant causing severe burns.**

On stock units, a plastic Coolant Reserve Tank is shipped loose from the generator set so that it can be mounted in a convenient and accessible location. A 21" hose is provided with the unit. The tank must be mounted vertically and no higher, lower or more distant than 21" of the radiator neck in order to operate properly – do not extend the hose length. If a longer run of hose is required, contact Cummins Atlantic's Engineering Department for recommendations and to assure that a longer run will operate properly in your installation. The recovery tank operates best when the top of the tank is at the same level as the radiator neck. Since the recovery tank operates on both positive and negative pressures, all hose connections must be tight.



FIG. 10 STANDARD COOLANT RESERVE TANK

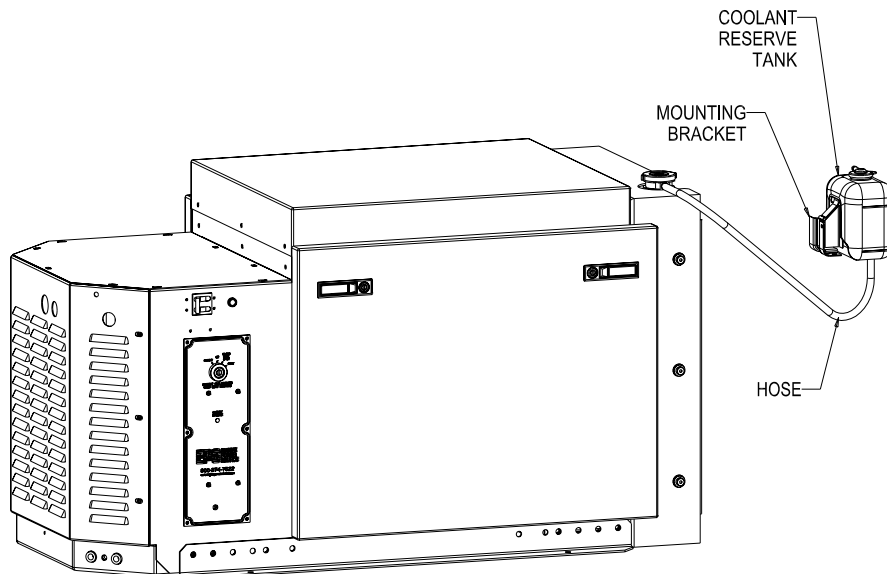

## FUEL CONNECTIONS

The fuel connections for the generator are located on the rear-bottom corner of the enclosure.

**⚠ WARNING: FIRE HAZARD! Diesel fuel is flammable. Fuel connections to the generator must be sealed with pipe sealant rated for use with diesel fuel. Fuel lines and connectors must be rated for use with diesel fuel. Avoid routing the fuel lines near hot areas or against sharp corners or edges that can cut through the line. Do not route fuel lines in close proximity with electrical lines. If the generator is installed in a bus bay or secondary enclosure, a weep hole in the floor of the enclosure must be provided to allow any fuel and/or oil that might leak to drain out of the compartment. Assure that this opening is kept clear at all times.**

FIG. 11 DIESEL FUEL CONNECTIONS

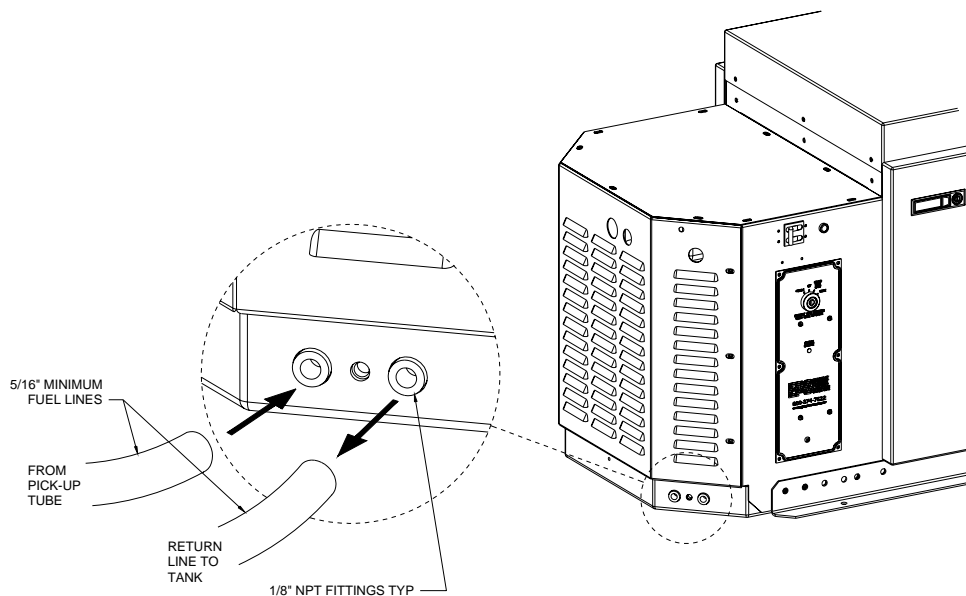

There are basically 2 options for providing fuel to the generator – each has its own benefits and drawbacks:

- 1) Use a Separate Fuel Tank: Using a separate fuel tank is by far the best solution as far as avoiding problems are concerned. The separate fuel tank prevents the generator from running the vehicle's fuel tank dry and leaving you stranded. It avoids the issues of "starving" one or the other engine of fuel when common fuel pick-ups and/or lines are used. Additionally, there is always a "back-up" fuel supply on board, should one or the other engine run out of fuel. Unfortunately, due to space concerns, this set-up is rarely practical.
- 2) Use the Vehicle's Fuel Tank: When using the vehicle's existing fuel tank, it is important to use a separate dip tube of shorter length for the generator. In that way, if the generator runs the tank down on fuel, there is always a little bit left for the vehicle engine. Using a separate dip tube avoids the issues of one engine "starving" the other for fuel. Tapping into the existing vehicle dip tube or fuel supply line should be avoided. At a minimum, this can lead to fuel starvation problems and in some cases, one engine can pull the fuel out of the other engine while it is not running, making it difficult or impossible to start. There is also the possibility of stranding the vehicle due to the generator running the tank out of fuel.

Electric Fuel Pump: The generator is equipped with an electric fuel pump to assure a good supply of fuel pressure to the engine. As with all pumps, the electric pump is better at "pushing" fuel than "lifting" it. In some cases where the fuel tank is located a long way from the generator or the fuel lines are routed a long distance, it may be necessary to remote-mount the fuel pump to assure a reliable fuel supply. Removing the fuel pump from the generator and mounting it near the fuel tank can easily accomplish this. The power supply wire, (Red/White-stripe), will need to be extended to the pump along with a ground wire running from the generator engine block.

Fuel Bleeding: There is a "Fuel Bleed-off" valve located on the fuel rack of the engine. This valve can be opened, (counter-clockwise), to allow air to be purged from the fuel lines and pump. To bleed the air from the fuel system, first, open the Fuel Bleed-off Valve about one turn." Bump" the STOP/START Switch momentarily to "START" – this will start the Electric Fuel Pump running for 30 seconds *without* starting the unit. Once the unit is primed, close the Fuel Bleed-off Valve. Don't forget to reset the electrical system by pushing the STOP/START Switch over to "STOP". Oftentimes, just running the fuel pump for one or two cycles without opening the Fuel Bleed-off Valve is enough to prime most fuel systems.

FIG. 12 FUEL BLEED-OFF VALVE

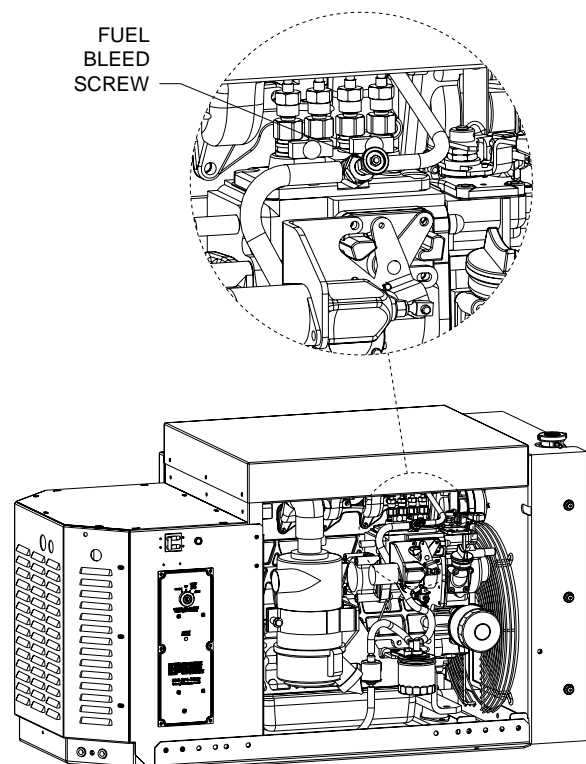

## **BATTERY CONNECTIONS**

The battery connections for the generator are located on the rear-bottom corner of the enclosure.

**⚠ WARNING: FIRE HAZARD! EXPLOSIVE BATTERY GASES!**  
**Batteries produce highly explosive gases when charging. Do not smoke or allow a flame or spark near a battery. The compartment containing the battery should be well ventilated to allow the explosive gases to escape. Do not mount the battery in the generator compartment.**

**⚠ CAUTION: OBSERVE CORRECT BATTERY POLARITY!**  
**When installing and hooking up a battery to the generator set, carefully observe the polarity of the connections. Battery positive (+) must be connected to the terminal marked “+” and negative (-) to the terminal marked “-“. Reversing the connections will cause a short circuit fault through the alternator which can cause alternator and wiring harness damage. Additionally, if jumpstarting a dead battery, correct polarity must be observed or severe damage to the unit and/or battery can result.**

FIG. 13 BATTERY CONNECTIONS

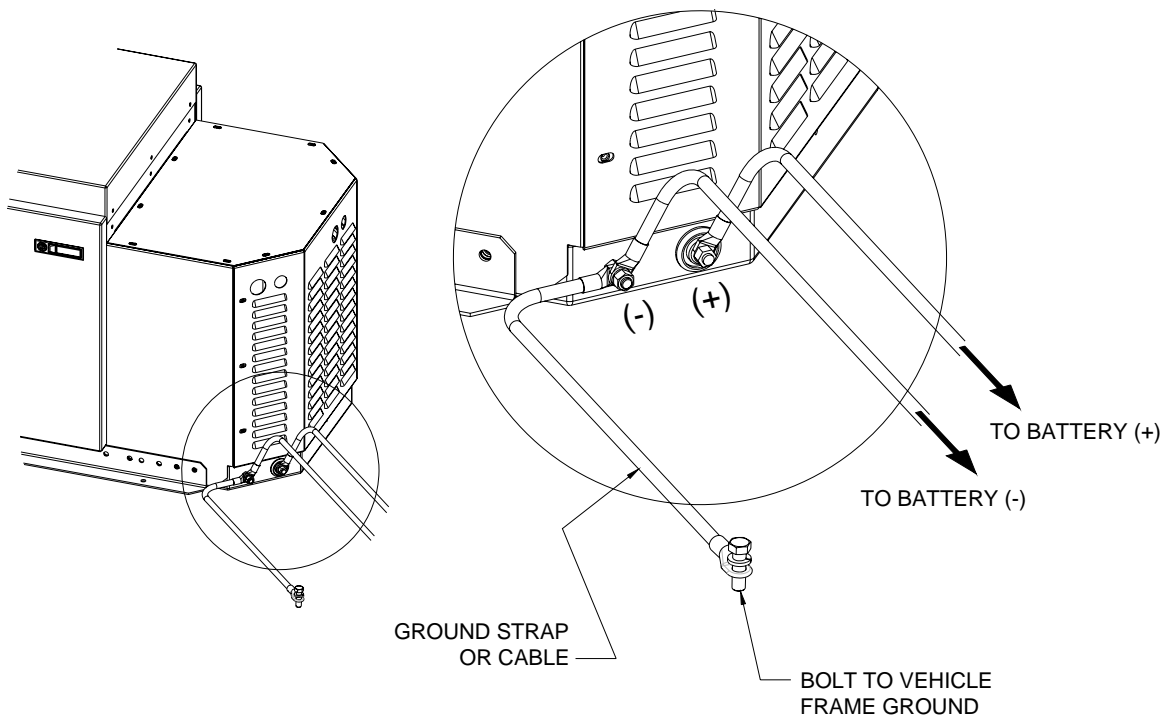

**FIG. 14 DEDICATED BATTERY**

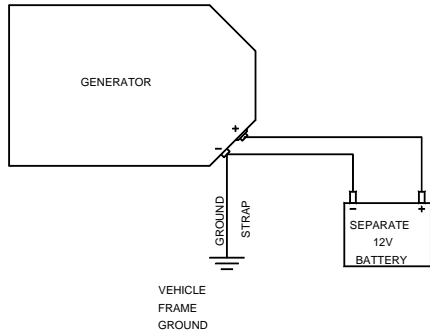

**FIG. 15 SHARED BATTERY**

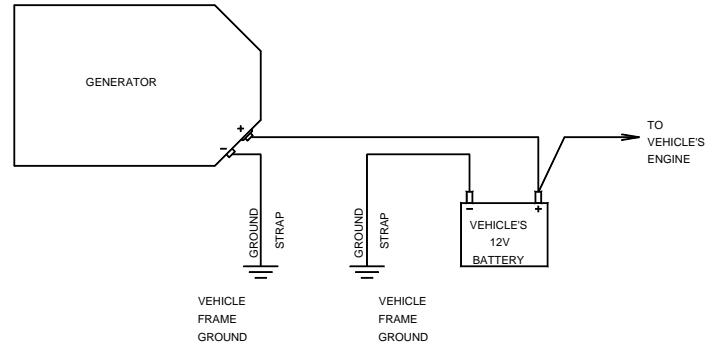

**Battery Cables:** Improper Battery and Cable sizing can lead to severe voltage drops – particularly on cold days when starting amps are highest and battery performance is at its lowest level. To avoid voltage drop problems, refer to the table below for *minimum* recommendations.

**TABLE 2: BATTERY & CABLE SIZING**

Engine Series	Minimum Battery CCA & Sizes	Minimum Cable Sizing
Kubota –03 Series	1000 CCA Group 31	#2 for < 5' #1 for 5' - 10' #1/0 for 10' – 20' #2/0 for 20' – 25'

**Ground Strap:** A Ground Strap must be installed between the Battery Cable GND (-) stud on the frame of the generator and the Vehicle Frame. The minimum size of the ground strap should be #2 AWG. In cases where the negative battery cable is not run directly to the battery, the ground strap size should be increased to the same size as the battery cable (see Table 2).

## **REMOTE START PANEL**

This generator is designed for use with a Remote Start Panel. The Remote Start Panel allows easy and convenient starting from up to 75 feet away. A 4-wire cable is included with the generator for use in connecting the generator to the Remote Start Panel. The cable comes in a standard length of 50' with mating connectors pre-installed. Other lengths are available upon request.

- ⚠ **CAUTION: The cable comes with mating connectors installed. Do not cut the cable and attempt to re-attach or splice it. The cable is made to be weatherproof and any splices made will allow water to enter the cable causing damage and malfunctions. If a cable is damaged during installation, contact CUMMINS ATLANTIC for a Cable Repair Kit.**
  
- ⚠ **CAUTION: The Remote Start Panel must be installed in a weather-protected location only. If the panel or its mating connector is subjected to moisture or dirt, malfunctions and damage can occur.**

The Remote Start Panel must be installed in a weather-protected location in the interior of the vehicle. A template for mounting the panel is included in the back of this manual.

When installing the cable, take care to route it in such a manner that it will not rub against any sharp edges or become pinched by any moving parts. Allow a little bit of slack at both ends, and coil up any excess cable and tie it off. Do not attempt to shorten or lengthen the cable by splicing it – splices open the cable up to moisture and dirt and will eventually lead to failure.

The Generator-end connector is a sealed circular connector. It mates to the connector on the pigtail coming from the rear of the unit. To mate the connectors, align the pins, push them together, and turn the locking ring to secure them.

**FIG. 16 REMOTE START PANEL CONNECTIONS**

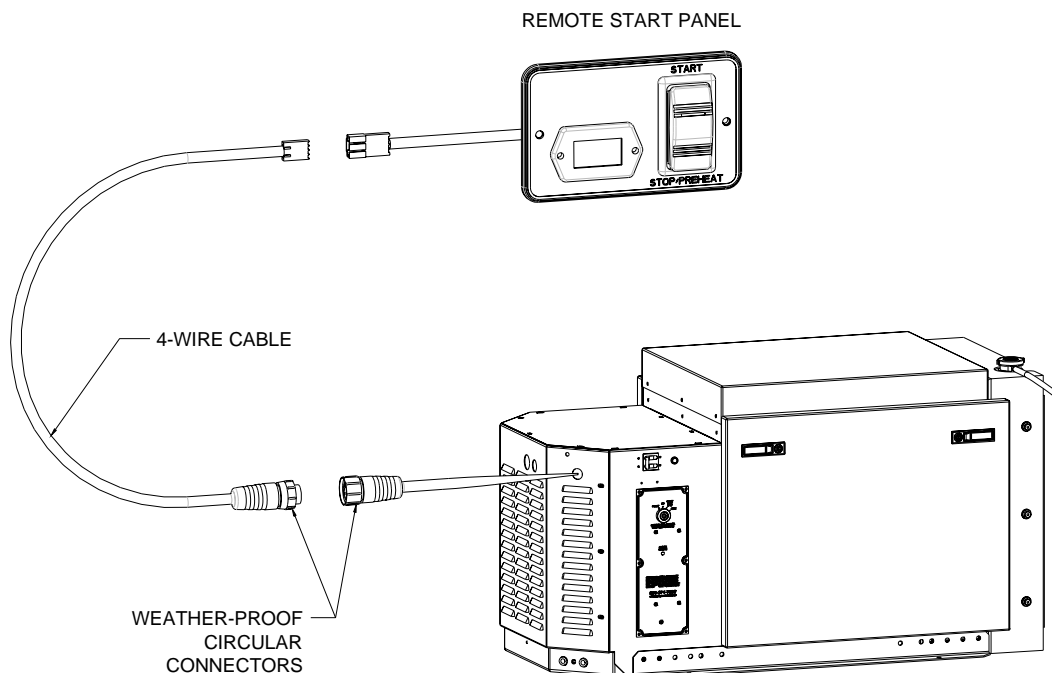

## OPTIONAL DELUXE GAUGE PANEL

An optional Deluxe Gauge Panel is also available for this unit. The Standard Gauge Panel includes analog Oil Pressure and Temperature gauges, Digital DC Volt Meter, Hour Meter and Start/Stop Rocker Switch.

In addition to the standard 4-wire remote panel cable, connections to the Temperature and Oil Pressure Gauges must be made using two #14 or larger wires. These 2 wires are not included with the generator, and must be supplied by the installer. Smaller wire sizes will result in unacceptable inaccuracies. Sending units are already installed and wired up to the Screw Terminal Strip on the Engine Control Board inside of the Main Control Panel. The two additional #14 wires must be connected to the appropriate positions on the Screw Terminal Strip. The Temperature Gauge “S” terminal must connect to the terminal marked “TMP” – which is the very last position on the terminal strip. The Oil Pressure Gauge “S” terminal must connect to the terminal marked “OIL” – which is the second-to-last position on the terminal strip. Refer to the “REMOTE START GAUGE PANEL” schematic, located in the SCHEMATICS section of this manual for wiring diagrams.

FIG. 17 OPTIONAL DELUXE GAUGE PANEL

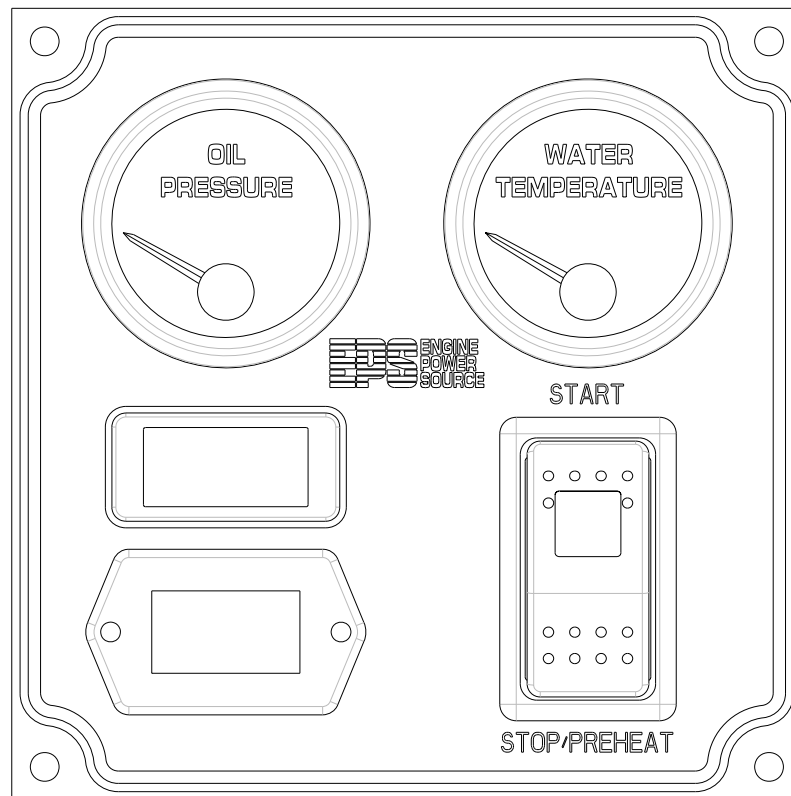

## **AC ELECTRICAL CONNECTIONS**

 **DANGER: HIGH VOLTAGE!** Risk of electrocution and death! **All electrical connections must be made by a qualified electrician in compliance with Article 551, NFPA 70, The National Electrical Code. Do not operate unit without all covers and guards installed.**

 **CAUTION:** This model generator is designed to operate at **120/240V AC only**. Do not attempt to reconnect it for 120V-only operation – the standard voltage regulator is not capable of operation at this voltage and may result in damage if operated in this manner. If you intend to operate the generator at 120V only, you must order a 120V voltage regulator kit from Cummins Atlantic. Contact **CUMMINS ATLANTIC Generator Sales** for details and availability.

**NOTE:** The generator neutral is bonded to frame ground.

Four connections must be made to the generator set for proper operation:

**L1 & L2 “Hot” Leads:** These connections should be made directly to the circuit breaker “Load” lugs. Use #4 AWG (minimum) size wire rated for at least 90° C (194° F). Black wire is typically used for L1, red wire is typically used for L2.

**Neutral “N” Lead:** This connection should be made directly to the terminal block located inside of the Generator Terminal Box. Connect to terminal “2”. Use #4 AWG (minimum) size wire rated for at least 90° C (194° F). White wire is typically used for the Neutral Wire.

**Ground “GND” Lead:** This connection should be made to the Ground Bolt Stud located inside of the Generator Terminal Box – designated by the  symbol. Use #6 AWG (minimum) size wire rated for at least 90° C (194° F). Green wire is typically used for the Ground Wire.

**NOTE:** 120V-only models will require #1/0 AWG (minimum) wires for Hot and Neutral and #1 AWG (minimum) for Ground in 1-1/2” conduit.

The AC power electrical connections should be made to the generator using liquid tight flex conduit. There are conduit knockouts pre-punched in the enclosure, located near the top-rear of the unit (see Figure 19). Conduit sizing is dependant upon the size of the wires used, but if the minimum sizes called out above are used, 1” liquid-tight non-metallic flexible conduit can be used.

Internal wiring should be routed and secured within the enclosure in such a manner that it will not contact any moving or hot parts. Secure the wires as required to prevent any chaffing of the insulation against any of the metal of the generator or enclosure. AC electrical wires should not be routed in such a manner as to avoid contact with any of the DC electrical harness. See Figure 18 for recommendations on routing and securing the AC wires.

**FIG. 18 AC ELECTRICAL WIRE CONNECTIONS & ROUTING**

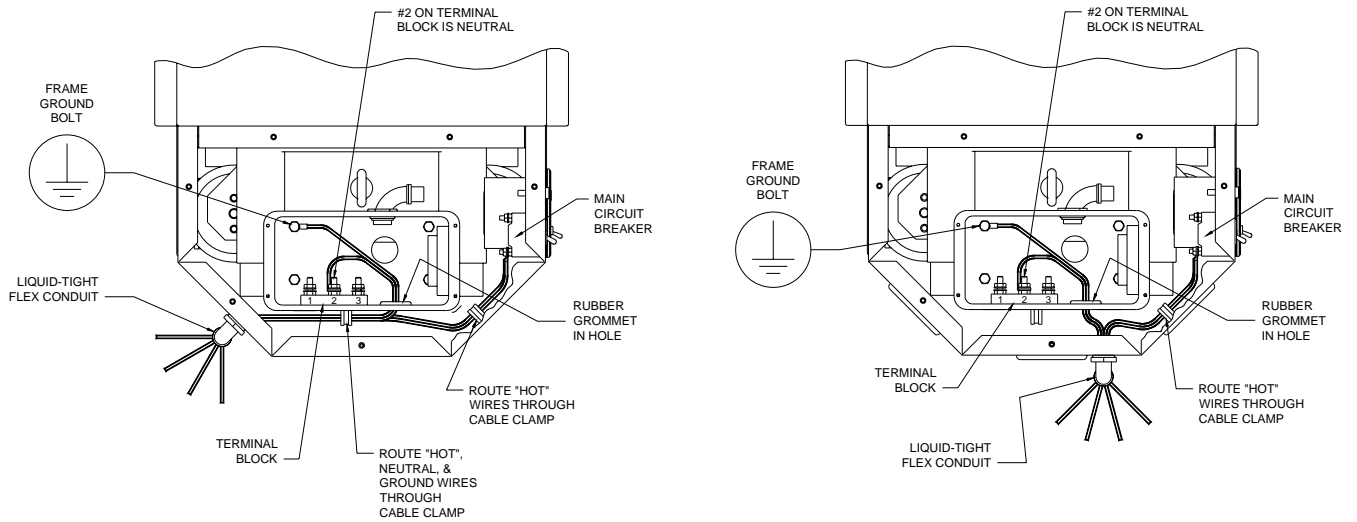

**FIG. 19 CONDUIT KNOCKOUT LOCATIONS**

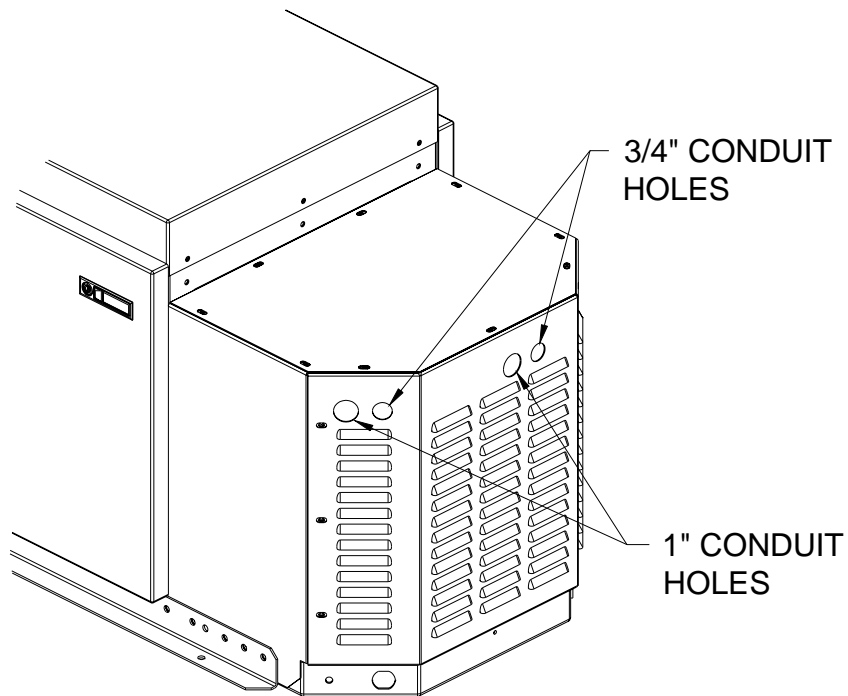

**⚠ CAUTION:** If this generator is used in an application where outside utility power, (shore power), or a secondary generator can also be connected, a transfer switch or similar device must be included to prevent L1, L2 and N of the two sources from being connected simultaneously. Failure to isolate these lines can result in severe damage to the generator end and any electrical equipment connected to it.



### **STARTING & STOPPING**

#### To start the unit from the Main Panel:

- 1) Turn the Master Key Switch to the “PREHEAT” position and hold it there for 10-15 seconds to pre-heat the engine. During this time, the Glow Plugs and the Fuel Pump will run.
- 2) Immediately following the preheat, turn the Master Key Switch all the way to the right to the “CRANK” position to activate the starter. Run the starter for no longer than 7 seconds.
- 3) If the unit fails to start, turn the Master Key Switch back to “OFF”, wait 30 seconds and repeat step 1 & 2. **NOTE:** *You must turn the Key Switch to “OFF” for at least a moment to clear the shutdown fault out!*

#### To start the unit from the Remote Start Panel:

- 1) The Master Key Switch must be in the “REMOTE START & RUN” position to enable starting from Remote Start Panel.
- 2) Push the Rocker Switch to its STOP/PREHEAT position and hold it there for 10-15 seconds to pre-heat the engine.
- 3) Immediately following the preheat, push and hold the Rocker Switch to its START position to activate the starter. Run the starter for no longer than 7 seconds.
- 4) If the unit fails to start, wait 30 seconds. Assure that the Master Key Switch on the Main Panel is turned to the “REMOTE START & RUN” position and repeat steps 2 & 3. **NOTE:** *You must preheat for at least a moment to clear the shutdown fault out!*

 **CAUTION: Avoid preheating the unit for longer than 15 seconds at a time. Longer preheat times will shorten glow plug life.**

#### To stop the unit from the Main Panel:

- 1) Turn the Master Key Switch to the “OFF” position. When the Master Key Switch is in the “OFF” position, the unit is shut down and cannot be started from the Remote Panel.

#### To stop the unit from the Remote Start Panel:

- 1) Momentarily push the Rocker Switch to its STOP/PREHEAT position. The green light should go out, indicating that the unit was shut down.

## ROUTINE MAINTENANCE

For *detailed* instructions concerning routine engine maintenance, refer to the Kubota Diesel Engine Manual included with the unit.

### **ENGINE OIL & OIL FILTER**

 **WARNING: Do not change the oil with the engine running. Allow the engine to cool down after running before changing the oil or filter – hot oil can cause severe burns.**

The “break-in” oil and oil filter should be changed after the first 50 hours of running. After that, the oil and oil filter should be changed every 200 hours. Oil grade should meet or exceed API type CD.

Ambient Temperature	Recommended Oil
Above 77°F (25°C)	SAE 30W SAE 10W-30 SAE 10W-40
32-77°F (0-25°C)	SAE 20W SAE 10W-30 SAE 10W-40
BELOW 32°F (0°C)	SAE 10W SAE 10W-30 SAE 10W-40

 **CAUTION: Always use Kubota factory replacement oil filters. Experience has shown that some aftermarket filters are overly restrictive, resulting in dangerously low oil pressures that can cause increased wear within the engine.**

Use Kubota replacement filter P/N: 70000-32091, available from Cummins Atlantic.

Take care to wipe up any spilled oil from the unit, vehicle compartment or ground. Dispose of the used oil and filter properly by taking it to a designated recycling center.

## FUEL FILTER

**⚠ WARNING: Do not change the Fuel Filter with the engine running. Allow the engine to cool down before doing in maintenance involving the fuel system. Diesel fuel is flammable! Do not smoke while working around the fuel system. Immediately wipe up any spills and check carefully for leaks after performing maintenance. Avoid getting diesel fuel on your hands and clothing. Fuel soaked rags should be properly disposed of and must not be stored on the vehicle or in the generator enclosure!**

The Fuel Filter should be changed every 400 hours. Use Kubota replacement filter P/N: 16631-43560, available from Cummins Atlantic.

When changing the filter, inspect the fuel lines for damage or wear. Cracked or heavily abraded lines should be replaced immediately to avoid a leak, which could cause a fire. Look carefully for leaks or areas moist with diesel fuel that might indicate the beginnings of a leak.

Following replacement of the fuel filter, it will be necessary to vent the air from the fuel system lines. Open the Fuel By-pass Valve, located on the Injector Pump to allow the air to be quickly vented from the system. After the unit has started and run for a few minutes, the Fuel By-pass Valve can be closed again.

Upon starting the unit after replacing the Fuel Filter, check for fuel leaks *very carefully*.

## AIR CLEANER FILTER

**⚠ CAUTION: Do not change the Air Cleaner Filter Element with the engine running. Take care not to damage the new filter element when installing and handling it. Never run the engine without a Filter Element installed.**

The Air Cleaner Element should be changed roughly every 600 hours. If the generator runs a great deal while the vehicle is traveling down the road, larger amounts of road dust may clog the filter sooner. If the unit only runs in a relatively clean environment, filter changes may not need to be as frequent.

A clogged Filter Element will result in reduced engine and generator performance. Heavily clogged filters can ultimately fail, resulting in damage to the engine.

An optional Filter Restriction Indicator can be purchased from Cummins Atlantic (P/N: RBX002250) and installed on the Air Cleaner. When the filter becomes significantly restrictive, the indicator “trips”, showing a redline in its site-glass window to alerting you to change the filter.

When changing the Filter Element, use a clean rag to wipe the dust from the inside of the Air Cleaner body. Squeeze the Vent Valve, (Duck Bill), to allow any large particles to fall out of the Air Cleaner. Take care to carefully seat the new element into the body so that it seals properly. Use Kubota Filter Element P/N: P82-1575.

FIG. 14 AIR CLEANER

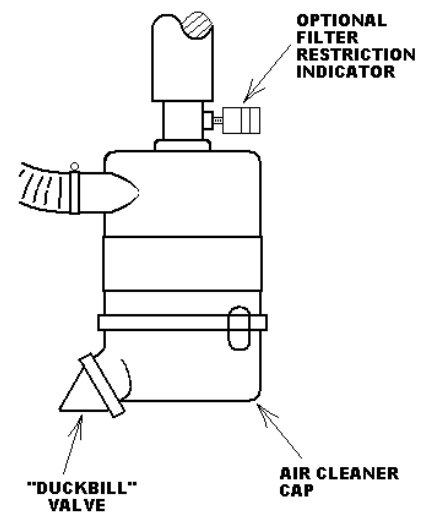

## **RADIATOR & COOLANT**

 **WARNING: Do not attempt to remove the Radiator Cap with the engine running or on a hot engine. Allow the engine to cool down for at least 30 minutes before doing in maintenance involving the radiator or cooling system. Radiators are under pressure and can spray steam and hot coolant causing severe burns.**

Radiator coolant levels should be checked frequently to avoid over-heating problems. A good rule of thumb is to check the coolant level in the Coolant Reserve Tank every 200 hours when the Oil and Oil Filter are changed. Top off the tank if necessary.

When checking coolant levels, inspect the Radiator Core. Over time, dirt and grime can build up between the fins of the core, reducing its cooling capacity. Eventually, the core will become dirty enough that the unit will over heat. Cores should be blown out with air or cleaned with a garden hose. Avoid using a high-pressure washer on the core as it can damage the cooling fins. Generators that are run while the vehicle is traveling tend to get plugged up more frequently.

The Radiator Coolant should be replaced annually or every 1500 hours – which ever occurs first. For all-weather operation, a solution of 50% distilled water to 50% ethylene glycol anti-freeze is recommended. Do not use pure anti-freeze in the engine – always use a 50/50 mixture!

Take care to wipe up any spilled coolant and to dispose of used coolant properly. Anti-freeze is a poison that is very hard on the environment and small amounts can poison pets if left out.

When replacing the coolant, take time to inspect the Radiator Hoses, Water Pump, Radiator and Reserve Tank lines. Old hoses can burst, causing a sudden loss of coolant, which can damage the engine. Hoses should feel firm when squeezed – a soft or cracked hose should be replaced. Check around the Water Pump for coolant leaks, which could indicate problems with hose connections or pump seals.

## **FAN & ALTERNATOR BELT**

 **WARNING: Do not attempt to inspect or tighten the belt with the engine running. Fingers and clothes can become entangled, causing serious injury.**

Inspect the fan/alternator belt annually or every 1000 hours. Fan belts can stretch over time, causing them to slip. For this reason, it may be necessary to tighten the belt on occasion to assure that it does not start slipping. Cracked, frayed or worn belts should be replaced as soon as possible to avoid a belt failure that could lead to over-heating.

## **ELECTRICAL WIRING**

 **WARNING: Do not attempt to inspect or repair the engine or generator wiring while the unit is running. Repairs to the generator AC wiring should be made by a qualified electrician. Always disconnect the battery positive (+) cable when inspecting or repairing the electrical system.**

### **ENGINE CONTROLS – PRINCIPLES OF OPERATION**

Please refer to the SCHEMATICS Section in the back of this manual for electrical diagrams.

 **DANGER: HIGH VOLTAGE! RISK OF ENTANGLEMENT!**  
**Before doing any work on the electrical panel or on the engine or generator, disconnect the battery positive (+) battery cable to prevent accidental or unintended starting.**

**MASTER KEY SWITCH:** Switches power to the Engine Control Board. Prevents starting and running when in the “OFF” position and enables starting and running when in the “REMOTE START & RUN” position. Also allows Preheating and Starting the engine from the Main Panel. Located on the Main Panel. When switched “OFF”, this switch effectively removes all power from the Start and Run circuitry of the Engine Control Board.

**“RUN” RELAY:** When activated momentarily by a start signal from either the REMOTE START PANEL (via diode D2), or the MASTER KEY SWITCH (via diode D1), this relay latches to provide continuous power to the SHUTDOWN & TIMER RELAYS (which control power to the engine loads). Diode D5 provides power feedback to the coil to latch the relay on. Diode D2 prevents power from feeding back to the “START” RELAY’s coil. Diode D1 prevents power from feeding back to the GLOW RELAY. This relay is replaceable, and is located on the Engine Control Board.

**“CRANK” RELAY:** When activated by a start signal from either the REMOTE START PANEL or the MASTER KEY SWITCH (via diode D7), this relay provides power to the STARTER. This relay is replaceable, and is located on the Engine Control Board.

**“SHUTDOWN” RELAY:** When deactivated, this relay allows power to flow from the “RUN” RELAY to the engine loads. When activated by one of the SHUTDOWN SWITCHES, this relay will remove power from the engine loads to shut the engine down. This relay is replaceable, and is located on the Engine Control Board.

**“GLOW/STOP” RELAY:** When activated by a glow/stop signal from the REMOTE START PANEL, this relay activates the coil of the GLOW RELAY, while simultaneously breaking power to the RUN RELAY (and therefore the loads, thus stopping the unit). In essence, this relay does double duty – allowing the same position on the Remote Start Panel Rocker Switch to stop the unit and activate the glow plugs. This relay is replaceable, and is located on the Engine Control Board.

**“GLOW” RELAY:** This relay supplies power to the GLOW PLUGS on the engine when activated by a “preheat” signal from the MASTER KEY SWITCH (via diode D3), or the REMOTE START PANEL (via the GLOW/STOP RELAY). It also activated (via diode D4), to supply power to the GLOW PLUGS while the engine is cranking. This relay is replaceable, and is located on the Engine Control Board.

**TIMER RELAY:** When power is first applied to this relay by the “RUN” RELAY, the contacts are pulled in for 30 seconds. This removes power from the coil of the “SHUTDOWN” RELAY, effectively by-passing the shutdowns for the first 30 seconds when the unit is started. This relay also provides a ground path for the coil of the “START” RELAY (via diode D6), for the first 30 seconds. This effectively locks out the “START” RELAY after 30 seconds, preventing

starter over-runs. Following a shutdown or a failed start attempt, this relay must be reset by providing a momentary stop signal from either the MASTER KEY or the REMOTE START PANEL. This relay is replaceable, and is located on the Engine Control Board.

**STARTER LOCK-OUT RELAY:** Essentially, this relay prevents running the starter once the unit is started. When deactivated, this relay allows the start signal from either the STOP-START SWITCH or the REMOTE START PANEL to be passed to the “START” RELAY’s coil. When the generator starts, and begins producing power, 120 VAC is provided from the generator to the coil of this relay via the STARTER LOCKOUT FUSE. When activated, the start signal is interrupted and power is fed back to the REMOTE START PANEL to light the lamp on the Rocker Switch and run the Hour Meter. This relay is located above the Main Panel, next to the Main Circuit Breaker. The Cover Plate above the Generator End must be removed to access this relay.

**“CHECK ENGINE” LAMP:** Located on the Main Panel. When the “SHUTDOWN” RELAY is activated, this lamp lights up to indicate that a fault has shut the engine down. The lamp will go out when the fault is reset by pushing “STOP” on the REMOTE START PANEL or switching the MASTER KEY SWITCH to “OFF”. This lamp is a solid-state LED, and should not require replacement.

**STARTER LOCK-OUT FUSE:** 120 VAC is provided to the STARTER LOCK-OUT RELAY’s coil via this fuse. It is located above the Main Panel near the Main Circuit Breaker. A 1 amp, 250VAC type MDA fuse is recommended.

**ENGINE LOADS:** The Engine Loads consist of the Fuel Solenoid Hold Coil, Electric Fuel Pump, and Alternator Field Coil. Power to these loads is provided by the “RUN” RELAY, via the “SHUTDOWN” RELAY and LOAD PROTECTION FUSE.

**STARTER FUSE (F1):** A 20-amp “mini” ATM blade-type automotive fuse is used to protect the Engine Controls in the event of a short circuit or overload associated with the MASTER KEY SWITCH, Starter, or Engine Control Board circuitry. This fuse is located on the Engine Control Board, inside of the Main Panel. The Main Panel must be removed and opened up to access this fuse.

**GLOW PLUG FUSE (F2):** A 40-amp ATO/ATC blade-type automotive fuse is used to protect the Engine Controls in the event of a short circuit or overload on Glow Plugs. This fuse is located on the Engine Control Board, inside of the Main Panel. The Main Panel must be removed and opened up to access this fuse.

**LOAD PROTECTION FUSE (F3):** A 10-amp “mini” ATM blade-type automotive fuse is used to protect the Engine Controls in the event of a short circuit or overload on any of the Engine Loads. This fuse is located on the Engine Control Board, inside of the Main Panel. The Main Panel must be removed and opened up to access this fuse.

**REMOTE HARNESS FUSES (F4 & F5):** Two 2-amp “mini” ATM blade-type automotive fuses are used to protect the Engine Controls in the event of a short circuit in the REMOTE START PANEL or its cable. These fuses are located on the Engine Control Board, inside of the Main Panel. The Main Panel must be removed and opened up to access these fuses.

**MAIN FUSE:** A 50-amp “maxi” blade-type automotive fuse is used to protect the entire Engine Electrical System. This fuse will be blown only in the event of a massive short circuit in the Engine Harness. This fuse is located on the Engine Harness, on the muffler-side of the engine, near the Starter. The Muffler-side Engine Access Door must be opened to access this fuse.

**SHUTDOWN SWITCHES:** Typically, only Low Oil and High Temperature shutdown switches are installed. These “combo” switch/sender units also include a resistive gauge sender terminal for use with the Optional Gauge Panel. In either case, a fault condition grounds the Gray/Red-stripe wire, to pull in the “SHUTDOWN” RELAY and shut the unit down. In order to allow oil pressure to fully build up when the engine is first started, these switches are by-passed for 30 seconds by the TIMER RELAY.

**GLOW PLUGS:** Located on top of the Engine Head, these electrical heaters are activated to preheat the engine head for reliable starting when the engine is cold. Power to the GLOW PLUGS is provided prior to starting by the GLOW/STOP RELAY and during starting by the “START” RELAY.

**JMP #1 & JMP #2:** Located on the Engine Control Board, these jumpers are normally placed across pins 1 & 2. When *both* jumpers are moved across pins 2 & 3, the TIMER RELAY is by-passed. If JMP #2 is removed, the emergency shutdowns are by-passed. JMP #1 & #2 are provided to aid in diagnosing problems.

**JMP #3:** Located on the Engine Control Board, this jumper is installed only when the optional Low Coolant Shutdown System is installed. Removing the jumper by-passes the low coolant shutdown function. Stock units are shipped without the jumper installed and without Low Coolant Shutdown. Low Coolant Shutdown may not be applicable to all models and radiator configurations – contact the factory for applicable models.

FIG. 20 ENGINE CONTROL BOARD

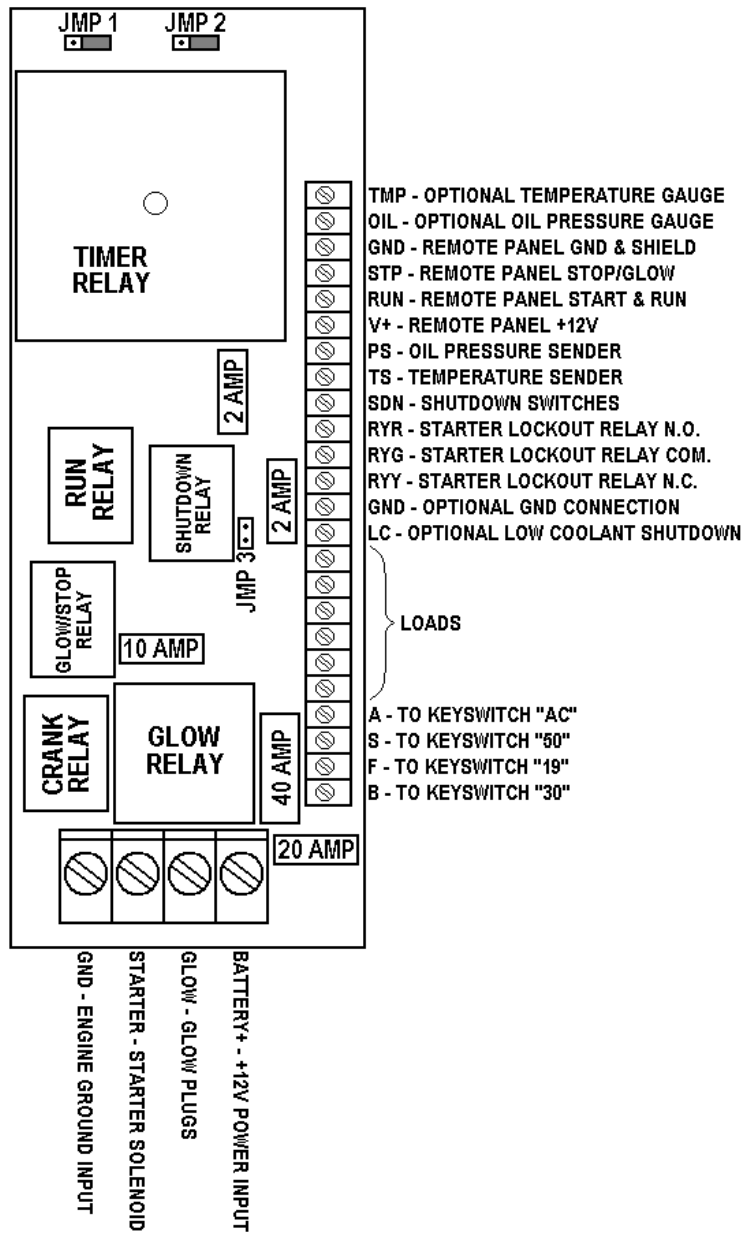

## **DIAGNOSING SHUTDOWNS**

If a fault is detected via the Shutdown Switches, the engine will immediately shut down and the "CHECK ENGINE" Lamp will light up. To diagnose which switch caused the fault, use a process of elimination by disconnecting the Gray/Red-stripe wire from one switch at a time and re-starting the unit. The unit should run for about 30 seconds (while the Timer Relay is bypassing the Shutdown Switches), before shutting down. If it keCummins Atlantic running, it is likely the switch that was disconnected that caused the shutdown fault.

## **LOW OIL SHUTDOWN SWITCH**

An Oil Pressure Sender/Switch Combo Unit is used on all currently produced units. Some older models may only have an Oil Pressure Switch. Refer to the pictures below to determine which switch your unit is fitted with.

### **How it Works**

The Oil Pressure Switch has a single screw connection on top. It is designed to close to ground at 7 PSI and below, and to remain open at pressures above 7 PSI.

The Oil Pressure Sender/Switch Combo Unit has two black screw-terminal knobs on top, which make connection to the resistive element and shutdown switch. Terminal markings are stamped into the metal body beside each terminal. The resistive element is marked "G" and the switch contact is marked "WK".

The switch contact is designed to close to ground at 7 PSI and below, and to remain open at 7 PSI and above. The resistive element is designed to measure a pressure range of 0 – 80 PSI. At 0 PSI, the resistive element will measure roughly 10Ω. The resistance increases with pressure, to a maximum of 180Ω at 80 PSI. The resistance will increase roughly 2.1Ω with every 1 PSI increase in oil pressure. For example: 40 PSI would result in ...  $(40 \times 2.1\Omega) + 10\Omega = 94\Omega$ .

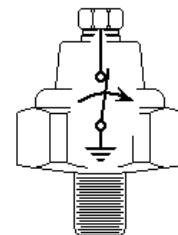

**SWITCH**

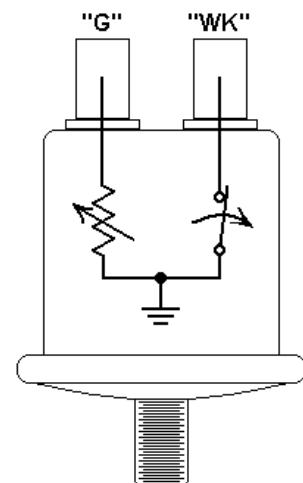

**COMBO  
SENDER/  
SWITCH**

## **Low Oil Pressure Shutdown Causes**

Low oil pressures can lead to severe damage to an engine, and should not be taken lightly.

First, check the obvious – is the engine low on oil? Is there any indication of a leak? Very low oil levels will result in low oil pressures, quickly leading to damage.

First thought is often to suspect a defective switch. However, before attempting to bypass an oil pressure sender, it is important to assure that the engine does indeed have adequate oil pressure. Temporarily replace the electrical sender with a mechanical oil pressure gauge, taking care to insulate the Gray/Red-stripe wire end removed from the switch. Inexpensive mechanical oil pressure gauges can be purchased at most auto parts stores, and are an invaluable tool for any mechanic to have.



When the engine is started and run with the mechanical gauge in place, oil pressure should rapidly build to roughly 40 PSI or higher. As the engine warms up, pressure should typically remain above 35 PSI. If the pressure is low or drops during the test, shut the engine down immediately – remember, you’ve disconnected the Low Oil Shutdown and you must carefully monitor the pressure to prevent damage should the pressure turn out to be low!

If the engine continues to shut down, the cause is not the Oil Pressure Switch – it is disconnected!

Replacement Low Oil Switches can be obtained from Cummins Atlantic (P/N: 15841-39010 Switch) or (P/N:360-009 Sender/Switch Combo Unit).

**NOTE: When replacing or re-installing the switch unit, do not use Teflon tape to seal the threads – the threads must make good electrical contact to the engine block. Loctite 567 Thread Sealant is used with excellent results on production units.**

If it turns out that the engine does have plenty of oil pressure, check for the following conditions, which may result in sending unit malfunctions:

Intermittent Short Circuit to Ground:

Sometimes, when the insulation on a wire becomes damaged or is “pinched” between metal surfaces, it will make intermittent contact to the metal while the engine is running – but will not make contact when the engine is stopped. These “running shorts” can be very difficult to diagnose. Wiggling the wires and harness along its length will sometimes reveal an intermittent short circuit.

Sender Wires Reversed:

When the Combo Switch/Sender is installed, assure that the Gray/Red-stripe Wire is connected to the “WK” terminal and the Blue wire is connected to the “G” terminal. If they are reversed, malfunctions in the shutdown system can occur.

If it turns out that the engine really is producing low oil pressure, check for the following conditions, which may result in low oil pressure:

Incorrect Oil Filter:

Although many different sizes and types oil filters can be found which will adapt to the engine, it is very important to use only approved or OEM oil filters. It is not uncommon for a “substitute” filter to restrict the flow of oil, causing low oil pressures and oil starvation.

Clogged or Faulty Oil Filter:

Replacing the Oil Filter will eliminate this possibility.

Other “Engine-related” Causes:

Some other possible causes for low oil pressure include: Blocked oil passages, worn bearing surfaces and a worn or damaged oil pump.

## **HIGH TEMPERATURE SHUTDOWN SWITCH**

A Temperature Sender/Switch Combo Unit is used on all currently produced units. It is mounted in the thermostat housing near the fan-end of the engine. Some older models may only have a Temperature Switch. Refer to the pictures below to determine which switch your unit is fitted with.

### **How it Works**

The Over-temperature Shutdown Switch has a single male .250" Fast-on connection on top. It is designed to close to ground at coolant temperatures above 220°F, and to remain open at all temperatures below that point.

The Temperature Sender/Switch Combo Unit has two male "tab-terminals" on top. This unit contains a resistive sender element and a shutdown switch. The *larger* of the two tab-terminals makes connection to the resistive element inside, and the smaller one connects to the switch contacts. The resistive element is designed to measure a temperature range of 70°F – 250°F. At 75°F, the resistive element will measure roughly 600 Ω. The resistance decreases *non-linearly* with temperature. The resistance at 140°F is roughly 135 Ω, and the resistance at 195°F is roughly 50 Ω.

### **High Temperature Shutdown Causes**

Excessive coolant temperatures can lead to severe engine damage, and should not be taken lightly.

As always, check the obvious – is the engine low on coolant? Is there any indication of a coolant leak? Is the ventilation system working properly (including any auxiliary fans)? Is the radiator plugged with dirt? All of these can lead to excessive temperatures.

When diagnosing over-temperature shutdowns, it is important to eliminate the possibility of a defective sender. Typically, a defective sending unit will shut a *cold* engine down within about 60 seconds of starting. However, before attempting to bypass a temperature sender, it is important to assure that the engine is not Running hot. Temporarily replace the electrical sender with a mechanical temperature gauge, taking care to insulate the Gray/Red-stripe wire end removed from the switch. Inexpensive mechanical temperature gauges can be purchased at most auto parts stores, and as with the mechanical oil pressure gauge recommended above, are invaluable tools for any toolbox.

Replacement switches and sending units can be obtained from Cummins Atlantic (P/N: NATS6642 Switch) and (P/N: 323-099 Sender/Switch combo unit).

**NOTE: When replacing or re-installing the electrical sending unit or switch, do not use Teflon tape to seal the threads – the threads must make good electrical contact to the engine block. Loctite 567 Thread Sealant is used with excellent results on production units.**

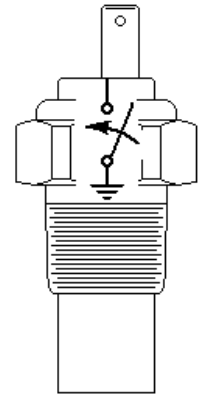

**SWITCH**

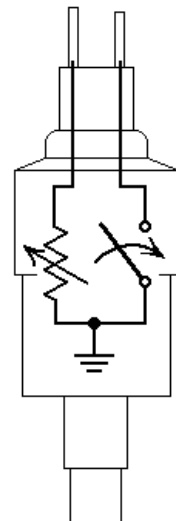

**OPTIONAL  
SENDER/SWITCH**

If it turns out that the engine is not running hot, check for the following conditions, which may result in sending unit malfunctions:

Intermittent Short Circuit to Ground:

Sometimes, when the insulation on a wire becomes damaged or is “pinched” between metal surfaces, it will make intermittent contact to the metal while the engine is running – but will not make contact when the engine is stopped. These “running shorts” can be very difficult to diagnose. Wiggling the wires and harness along its length will sometimes reveal an intermittent short circuit.

If it turns out that the engine really is running hot, check for the following conditions, which may result in over-temperature:

Dirty or Blocked Radiator:

Inspect the radiator fins carefully. Over time, radiators tend to accumulate dirt and debris, which blocks the airflow through the radiator. The dirtier the environment, the less time it takes for the radiator fins to get loaded up with dirt. Use a garden hose with a spray nozzle to clean the dirt from the fins. Do not use a pressure washer – the high pressure from a pressure washer can literally tear the radiator fins and tubes apart!

Inadequate Ventilation:

The radiator and generator end need a continuous supply of cool air to work properly. Assure that all supplemental cooling fans are working properly. In some installations, it is possible for the hot air coming from the generator or radiator to be re-circulated back through the radiator, causing excessive temperatures. This will usually show up shortly after the generator is installed or on the first hot day after installation. Naturally, the only solution is to improve the air supply to the radiator. Refer to the Installation Section of this manual or contact CUMMINS ATLANTIC’s Engineering Dept. for generator installation recommendations.

Air Pocket in Cooling System:

When the coolant is drained and changed in the cooling system, it is possible for an air pocket to form, which prevents the water pump from being able to pump coolant. Typically, this occurs most frequently on Remote-mount Radiator and Remote Mount Fill Tank installations. Air Vents are typically supplied on remote radiators to allow venting the excess air from the system while it is being filled. Air Pockets can be very difficult to diagnose – since little or no coolant is flowing, the engine overheats very rapidly - which can lead one to believe that it is merely a defective sending unit. Often times, when the temperature sensor is removed and replaced, the air pocket is vented out, “accidentally” correcting the real problem, *and making you believe that it really was a defective sending unit.* After 2 or 3 sending units have been replaced over time, it will become apparent that something more sinister is at play... remember to vent the air when replacing coolant!

Other “Engine-related” Causes:

Some other possible causes for high engine temperature include: Failed or damaged Water Pump, loose or broken belts, a wrong or damaged thermostat,

no thermostat installed, blockages inside of radiator or cooling system, and incorrect coolant mixtures (always use 50/50 coolant mixture).

## **BLOWN FUSES**

**LOAD PROTECTION FUSE (F3):** Should a short circuit or overload occur on the engine loads, the 10 amp Load Protection Fuse will blow. When this happens, the unit will stop. The “CHECK ENGINE” light will not light up. The next time the unit is started, the Fuel Solenoid will “rattle” due to the absence of power on the “hold” wire. The unit may start, but it will immediately shutdown in less than a second. Repeated attempts to start the unit can ultimately lead to Fuel Solenoid failure due to overheating, so it is important to recognize these symptoms and take corrective action. The Load Protection Fuse is located inside of the Main Panel on the Engine Control Board.

First, and foremost, inspect the electrical system on the unit for any indications of a short circuit, damaged wiring or other condition that might have caused the fuse to blow. Although it can happen, fuses rarely fail on their own – it typically takes an overload to cause them to blow. For that reason, it is best to locate the root cause for the blown fuse before investing in several more to convince yourself that there really was a problem...

The Glow/Stop, Run, Shutdown and Timer Relays are fed by this fuse. Check the operation of each relay to assure that the short circuit is not internal to it. These relays are located on the Engine Control Board and can be *carefully* pried out of their sockets with a small screwdriver.

Once the problem that caused the fuse to blow has been located and corrected, replace the blown fuse with another 10 amp, mini-type ATM automotive fuse. Do not substitute a fuse of a higher rating than this as the wiring is not sized for increased current beyond 10 amps.

**STARTER FUSE (F1):** The Starter Fuse protects the power supplied to engage the Starter Solenoid. It also feeds power to the Engine Loads via Master Key Switch and the Load Protection Fuse (F3). When this fuse is blown, the engine will not run or start.

Check the wires running to the Master Key Switch for any indications of a short circuit. Inspect the Key Switch for any damage which could lead to a short circuit. Also check the PURPLE 14G Wire running from the Engine Control Board to the Starter Solenoid. If any of the other fuses blew at the same time, inspect the circuits fed by those fuses first – a severe short circuit can, in rare cases, result in multiple fuses being blown. All of the relays on the Engine Control Board, (with the exception of the Glow Relay), are ultimately fed by this fuse. Check the operation of each relay to assure that the short circuit is not internal to it. The relays can be *carefully* pried out of their sockets with a small screwdriver.

Once the problem has been located and corrected, replace this fuse with another 20 amp, mini-type ATM automotive fuse. Do not substitute a fuse of a higher rating.

**GLOW PLUG FUSE (F2):** This fuse protects the Glow Plug Circuit. When the fuse is blown, the Glow Plugs will not operate, making it difficult to start the unit when it is cold.

Check the Yellow 10G wire running from the Engine Control Board to the Glow Plugs for damage (this is the only wire fed by this fuse). Also check the integrity of the Glow Plugs, and inspect the Power Buss Rail that they are connected to for any short circuits to the engine block. The Glow Relay is also fed by this fuse – check the operation of this relay to assure that the short circuit is not internal to it. This relay is located on the Engine Control Board and can be *carefully* pried out of its socket with a small screwdriver. Once the problem has been located and corrected, replace this fuse with another 40 amp, type ATO/ATC automotive fuse. Do not substitute a fuse of a higher rating.

**REMOTE HARNESS FUSES (F4 & F5):** There are two fuses that protect the electrical system from short circuits or overloads arising in the Remote Start Panel and its cable. These fuses are located inside of the Main Panel on the Engine Control Board. Should a fault occur, either fuse – or both fuses may be blown. One fuse protects the power feed to the Remote Start Panel that controls the starting and stopping functions. The other fuse protects the power feed that is used to run the green light in the Rocker Switch and the Hour Meter.

Inspect the Remote Start Panel wiring for damage that could have led to an overload. Also inspect the cable along its length to assure that it has not been pinched cut or abraded. To check the cable integrity, disconnect both ends of the cable. Using a digital ohmmeter, probe between each of the pins on the connector on the panel-end of the cable. Resistance between all of these pins should be very high – greater than 1MΩ. On most meters, this will read as an open circuit. Also probe between each pin and frame ground of the vehicle. If the cable insulation has abraded through or been pierced, some resistance should show between one of the pins and the frame.

Replace these fuses with 2 amp mini-type ATM automotive fuses. Do not substitute a larger value fuse!

**STARTER LOCK-OUT FUSE:** Should any kind of fault, overload or short circuit occur on the 120 VAC power feeding the coil of the Starter Lock-out Relay, this fuse will blow. When this happens, the Green Light on the Remote Start Panel will fail to come on and the Hour Meter will not run. Additionally, the Starter will not be locked out from being activated while the unit is running.

Inspect the electrical wiring leading to the Starter Lock-out Relay from the Generator End and from the Main Circuit Breaker. Also inspect the condition of the Starter Lock-out Relay – particularly its coil.

Once the problem that caused the fuse to blow has been located and corrected, replace the blown fuse with another 1 amp, 250VAC, Slo-Blo™, type MDA 1-1/4" x .25" fuse. Do not substitute a fuse of a higher amperage rating. Replacement fuses can be obtained from Cummins Atlantic (P/N: 46151).

**MAIN FUSE:** A single 50 amp Maxi Fuse located near the Starter on the engine protects the entire wiring harness. In the event of a severe short circuit or overload that fails to cause one of the other fuses to blow, this fuse will blow. It protects the main battery positive power feed from the starter to the electrical system of the generator. If this fuse is blown, the unit will not start or run.

Since all of the power used by the electrical system must first pass through this fuse, the problem could be located just about anywhere. Fortunately, it is very uncommon for a fuse of this size to blow as it takes a fairly severe overload or short circuit to exceed the fuse rating. For that reason, the failure point should be fairly apparent. Inspect the harness and panel wiring carefully. Check the other fuses – if one of them blew at the same time, it will help you narrow down the search for the fault.

The fuse can be replaced by removing the alternator-side door. It is located just to the right of the Starter, on the engine harness. There is a weather-tight cover over the fuse, which must first be pulled off. Replace this fuse with a 50-amp Maxi-type automotive fuse. Do not substitute a fuse of a higher rating.

**AC VOLTAGE REGULATOR FUSE:** On models equipped with a Marathon Pancake Generator End, the generator Voltage Regulator is protected by a single 4 amp time-delay fuse located on the back of the voltage regulator – which is located inside of the generator terminal box. In the event of a severe sustained overload or short circuit on the generator, this fuse may blow. This generally results in no voltage output from the generator.

Replace this fuse with a 4-amp type GDC-4A (5mm x 20mm) glass fuse. Do not substitute a fuse of a higher rating or of a different type. These fuses can be difficult to find, however, replacement fuses can be obtained from Cummins Atlantic (P/N: GDC-4A).

Models equipped with optional Newage Generator Ends do not have a voltage regulator fuse.

# ***PARTS LIST***

# ***ELECTRICAL DIAGRAMS***



REV	DATE	REVISION	BY
A	-	RELEASED FOR PRODUCTION	-

- NOTES:
- 1) DC VOLT METER IS OPTIONAL. SPECIAL ORDER ONLY.
  - 2) USE 14G WIRE (MINIMUM) FOR GAUGE SENDER LEADS (BLUE AND BROWN), CONNECT LEADS TO THE APPROPRIATE POINTS ON THE TERMINAL STRIP LOCATED INSIDE OF THE CONTROL PANEL.

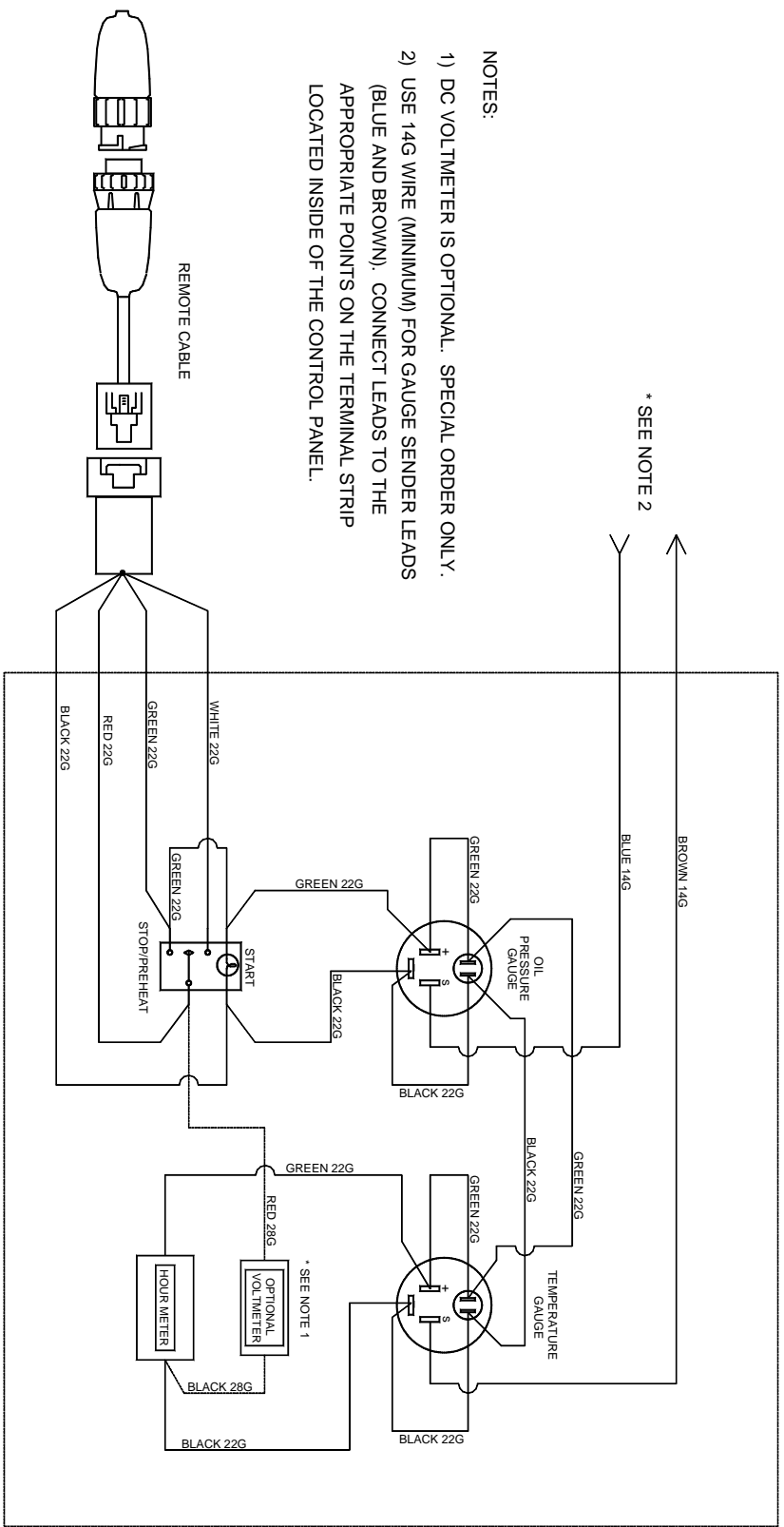

NO SCALE ACAD

This Document and all information contained in this document are confidential and proprietary to EPS. Unauthorized possession or use thereof is prohibited. This document, or any part hereof, or any information contained herein, may not be duplicated, reproduced, or disclosed to any person for any purpose except as specifically authorized in writing by EPS. By accepting this document, recipient agrees to comply with the foregoing and to return this document to EPS immediately upon request. Unpublished—All rights reserved under copyright laws.

EPS	ENGINE POWER SOURCE	220 Olympic Street, Charlotte, NC 28273 Phone: 704-553-7286 Fax: 704-588-9719	CAD BY CW	DATE 7-15-04	SHEET NUMBER 1 OF 1	UNSPECIFIED TOLERANCES ANGULAR _____ 1/2" FRACTION _____ .015 .XX _____ .010 .XXX _____ .005
PART NUMBER EPS2766	REVISION A	DESCRIPTION SCHEM, REMOTE START GAUGE PANEL	MATERIAL -	ADDITIVE FINISH -		

REV	DATE	REVISION	BY
A	-	RELEASED FOR PRODUCTION	-

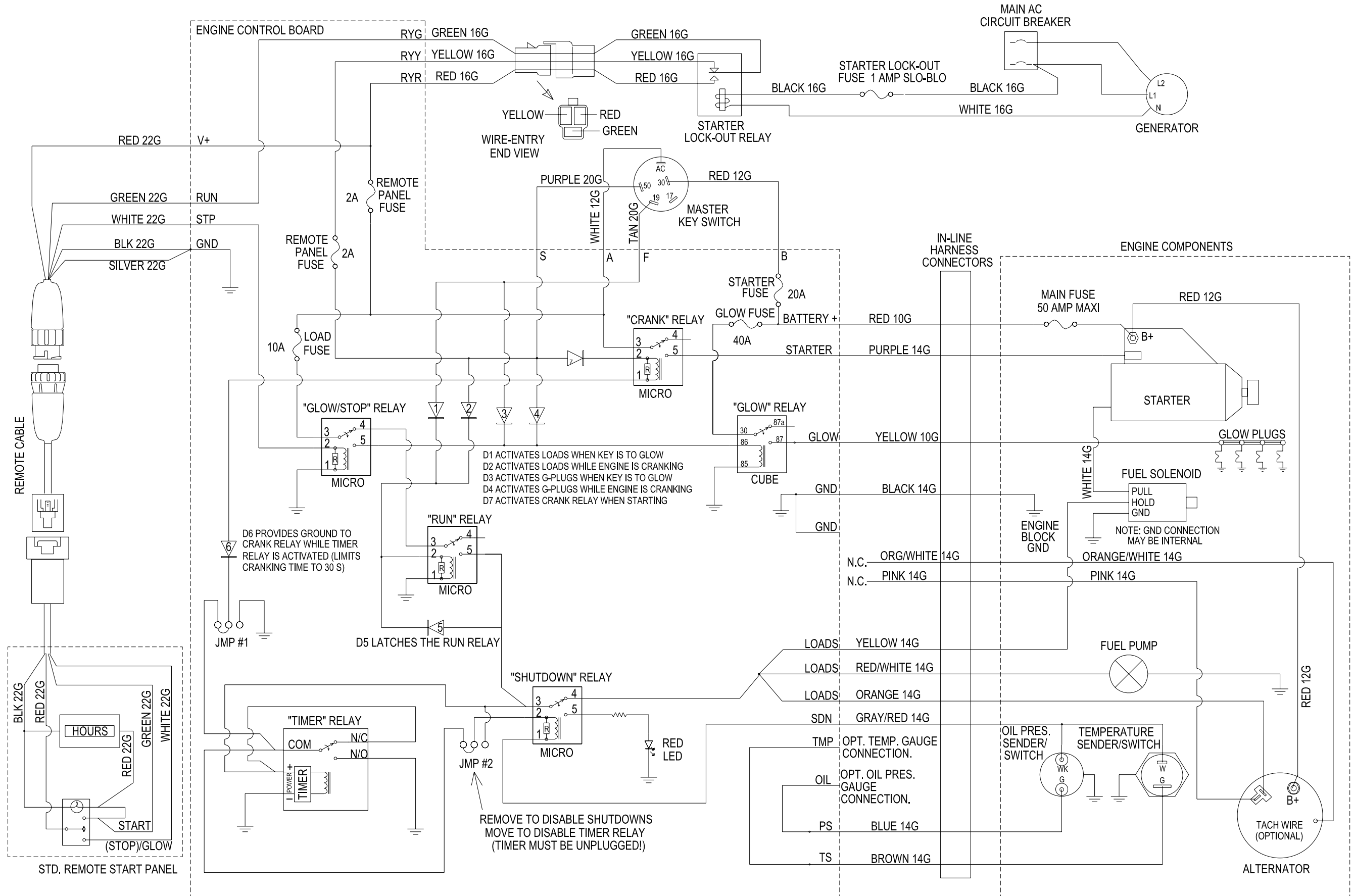

UNSPECIFIED TOLERANCES	ANGULAR 1/2°	FRACTION .015	XX	.XXX
SHEET NUMBER	1 OF 1			
DATE	2/21/05			
CAD BY	CW			
MATERIAL	-			
REVISION DESCRIPTION	SCHEM. ENC GENSET W/ RELAY BOARD			
ENGINE POWER SOURCE	EPS3078			
220 Olympic Street, Charlotte, NC 28273	Phone: 704-553-7286 Fax: 704-588-9719			